

Accom[®]

Axial[®] / **MX**

Installation Guide

Axial/MX • Installation Guide

Copyright

© Accom, Inc. May, 2005

No part of this publication may be reproduced, transmitted, transcribed, stored in a retrieval system, or translated into any languages in any form by any means without the written permission of Accom.

Notice

The information in this guide is subject to change without notice or obligation, and does not represent a commitment on the part of Accom, Inc.

Acknowledgments

Registered product trademarks or names used in this manual are the exclusive property of that equipment or software manufacturer. Their usage in this manual is with beneficial intention only.

Part Number

9100-0414-01

Company Address

Accom, Inc.
1490 O'Brien Drive
Menlo Park, California 94025
USA

- Phone: (650) 328-3818
- Fax: (650) 327-2511

FCC Compliance and User Information

The following information has been provided to clarify FCC requirements for operation of this device. These requirements are found in the FCC rules for radio frequency devices, Part 15.

Compliance

This equipment has been tested and found to comply with the limits for a Class B digital device pursuant to Part 15 of the FCC Rules. These limits are designed to provide reasonable protection against harmful interference when the equipment is operated in a commercial environment. This equipment generates, uses, and can radiate radio frequency energy and, if not installed and used in accordance with the instruction manual, may cause harmful interference to radio communications. Operation of this equipment in a residential area is likely to cause harmful interference in which case the user will be required to correct the interference at his or her own expense.

Important - Modifications & Shielded Cables

Changes or modifications to this product not authorized by Accom, Incorporated could void the FCC Compliance and negate your authority to operate the product.

This product was tested for FCC compliance under conditions that included the use of Accom peripheral devices and Accom shielded cables and connectors between system components. It is important that you use Accom peripheral devices and shielded cables and connectors between system components to reduce the possibility of causing interference to radios, television sets, and other electronic devices. You can obtain Accom peripheral devices and the properly shielded cables and connectors through an Accom-authorized dealer.

Safety and First Aid

Accom equipment is designed to the highest standards of quality and reliability. However, no matter how these systems are designed, operators and maintenance personnel can be exposed to electrical shock hazard when protective covers are removed for maintenance or the installation of options. With this caution in mind, each operator and engineer must observe all safety regulations, and have a clear understanding of first aid procedures related to electrical hazards.

Axial/MX contains CD-ROM Drive therefore the following CLASS 1 LASER PRODUCT warning is necessary when working with the CD-ROM. CAUTION: Invisible laser radiation when open. Do not stare into beam or view directly with optical instruments.

Safety and Compliance Certifications

- Conforms to UL STANDARD 1950
- Certified to EN60950



Power Information

This device is supplied with two power cords. One is for use in the United States and those areas where a North American style cord can be used. A second power cord is provided for international use. The international cord has a receptacle on one end for fitting to the Accom hardware and three pre-stripped wires on the remaining end, ready for installation of the proper international plug (supplied by the customer).

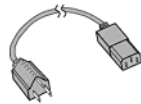

North American



International IEC 320

To ensure safe operation and to guard against potential shock or risk of fire, ensure that your power source is within the required voltage range and frequency for which the Axial/MX power supply has been set (115V, 60Hz or 230V, 50Hz).

- Input AC Power Requirement: 100 - 127V ~ / 10A 60HZ
- Input AC Power Requirement: 200 - 240V ~ / 5A 50HZ

Operating Environment



The Axial/MX optimum operating environment is within the following ranges:



- Recommended Operating Temperature: 20°C to 35°C (68°F to 95°F)
- Recommended Operating Humidity: 20% to 80% non-condensing

Note

High temperature/humidity should be avoided at all times.

Safety Information

中文	警告!	重要安全注意事项			
本系统遵守安全标准 IEC/EN60950。为确保安全操作及防止电击或火灾危险，请遵守以下规定： <ul style="list-style-type: none"> · 本系统能够自动调整以适应供电情况。请确保贵处的电源符合本系统所要求的正确电压和频率工作范围。 · 本系统中的每个机壳都必须接地，方法是将输入电源线连接到正确接线并接地的电源插座上。 · 对于随本系统提供的输入电源线，必须按如下方式接线： <table style="width: 100%; border: none;"> <tr> <td style="text-align: center;">载电线 = 棕色</td> <td style="text-align: center;">中性线 = 蓝色</td> <td style="text-align: center;">地线 = 绿色/黄色</td> </tr> </table> 			载电线 = 棕色	中性线 = 蓝色	地线 = 绿色/黄色
载电线 = 棕色	中性线 = 蓝色	地线 = 绿色/黄色			
	在从机壳取下顶盖之前，必须从机壳完全断开所有的输入交流电源线。否则将会暴露于危险电流及电压之下。身体接触这些电流和电压非常危险，并可能导致严重的人身伤害或伤亡！只有合格的服务人员才可以取下机壳的顶盖。				
	对于带有此标记的组件，可以在系统运行（带电）时取下。在取下组件之后，请当心机壳内组件插孔连接器上暴露的危险电流及电压。当机壳接通输入交流电时，请勿用手指、工具和外部金属物体接触裸露的插孔连接器。身体接触这些电流和电压非常危险，并可能导致严重的人身伤害或伤亡！只有合格的服务人员才能取下这些组件。				

ENGLISH	WARNING!	IMPORTANT SAFETY NOTICES			
This system complies with safety standard IEC/EN60950. To ensure safe operation and to guard against potential shock hazard or risk of fire, the following must be fulfilled: <ul style="list-style-type: none"> · This system features auto-ranging power supplies. Ensure that your power source is within the correct operating range of voltage and frequency, as required by the system. · Each chassis in this system must be electrically grounded by connecting the input power cord(s) to a correctly wired and grounded power outlet. · The input power cord(s) supplied with this system must be wired as follows: <table style="width: 100%; border: none;"> <tr> <td style="text-align: center;">Live = Brown</td> <td style="text-align: center;">Neutral = Blue</td> <td style="text-align: center;">Earth = Green/Yellow</td> </tr> </table> 			Live = Brown	Neutral = Blue	Earth = Green/Yellow
Live = Brown	Neutral = Blue	Earth = Green/Yellow			
	Completely disconnect <u>all</u> input AC power cords from chassis before removing top cover from chassis. Failure to do so will expose dangerous electric currents and voltages. Physical contact with these electric currents and voltages is extremely dangerous and may result in severe physical injury or death! Only qualified service personnel should remove the top cover from the chassis.				
	Modules marked with this symbol may be removed while the system is operating (powered). After removing a module, beware of dangerous electric currents and voltages that are exposed on the module receptacle connector inside the chassis. Please keep fingers, tools, and foreign metal objects away from the exposed receptacle connector while the chassis has input AC power applied. Physical contact with these electric currents and voltages is extremely dangerous and may result in severe physical injury or death! Only qualified service personnel should remove these modules.				



DEUTSCH	ACHTUNG!	WICHTIGE SICHERHEITSHINWEISE			
Dieses System erfüllt den Sicherheitsstandard gemäß IEC/EN60950. Um einen sicheren Betrieb sowie Schutz vor Stromschlag oder Feuer zu gewährleisten, muss folgendes beachtet werden: <ul style="list-style-type: none"> · Dieses System verfügt über eine variable Stromversorgung. Stellen Sie sicher, dass die Stromquelle über die korrekte, für das System vorgeschriebene Spannung und Frequenz verfügt. · Jedes einzelne Gehäuse des Systems muss elektrisch geerdet werden, indem die Netzkabel an eine ordnungsgemäß verdrahtete und geerdete Steckdose angeschlossen werden. · Die Netzkabel, die mit diesem System geliefert werden, müssen wie folgt verdrahtet sein: <table style="width: 100%; border: none;"> <tr> <td style="text-align: center;">Phase = Braun</td> <td style="text-align: center;">Null = Blau</td> <td style="text-align: center;">Schutz = Grün/Gelb</td> </tr> </table> 			Phase = Braun	Null = Blau	Schutz = Grün/Gelb
Phase = Braun	Null = Blau	Schutz = Grün/Gelb			
	Trennen Sie <u>alle</u> Netzkabel vom Gehäuse, bevor Sie die obere Gehäuseabdeckung entfernen. Wenn Sie diese Sicherheitsmaßnahmen nicht beachten, werden Sie gefährlicher elektrischer Spannung ausgesetzt. Wenn Sie mit dieser extrem gefährlichen elektrischen Spannung in Berührung kommen, kann dies zu Gesundheitsschäden oder sogar zum Tod führen. Die obere Gehäuseabdeckung sollte nur von geschultem Service-Personal entfernt werden.				
	Module, die mit diesem Symbol gekennzeichnet sind, können während des Betriebs (bei eingeschalteter Stromversorgung) entfernt werden. Wenn Sie ein Modul entfernt haben, schützen Sie sich vor elektrischer Spannung, die an der Anschlussdose innerhalb des Gehäuses freigesetzt wird. Berühren Sie die freigelegte Anschlussdose erst dann mit Fingern, Werkzeug oder Metallgegenständen, wenn die Stromzufuhr zum Gehäuse unterbrochen ist. Wenn Sie mit dieser extrem gefährlichen elektrischen Spannung in Berührung kommen, kann dies zu Gesundheitsschäden oder sogar zum Tod führen. Diese Module sollten nur von geschultem Service-Personal entfernt werden.				



Table of Contents

Chapter 1	Introduction	1
	In This Guide	1
	Installation Guide Introduction	1
	How to Use This Guide	2
	Navigating and Searching	2
	Table of Contents and Index	2
	Terms and Conventions	3
	Contacting Accom	4
	Axial Technical Support	4
	World Wide Web	4
	Axial Specfile Resources	4
	System Overview	5
	System Diagram	5
	Recommendations	6
	System Processing	6
	525 / 625 Operations	6
	Physical Components	6
	Main Chassis Architecture	6
	Control Panel	7
	Display Monitor	7
	Maintenance Keyboard and Mouse	7
	System Options	7
	External Communication	8
	Comms Port Communications	8
	GPI Outputs	9
	Display Chassis to Comms Chassis Link	9
	Control Panel Port	9
	Display Monitor	9
	Printer	9
	Ethernet	9
	Video I/O	9
	Data Storage and Transfer	10
	Maintenance	10
Chapter 2	Installation	11
	In This Chapter	11
	Safety Precautions	12
	Unpacking and Inspection	13
	System Option Keycode Sheet	13
	Shipping Brackets	13

Table of Contents

Power Consumption	14
Chassis	14
Control Panel	14
Cooling and Airflow	15
Site Preparation	16
Physical Installation	17
Display Chassis Rack Mounting	17
Comms Chassis Rack Mounting	19
Control Panel Mounting	21
Control Panel External Power Supply	22
Software Installation	22
Chapter 3 System Connectors	23
In This Chapter	23
Display Chassis Rear Panel Connectors	24
Comms Chassis Rear Panel Connectors	26
Display Chassis Front Panel Connectors	29
Control Panel Connections	29
Connector Pinouts	30
RS-422 Connectors	30
GPI Connectors	31
RS-232 Serial Connector	32
Parallel Printer Connector	33
Ethernet Connectors	34
Crossover Cable	34
VGA Connectors	35
Chapter 4 System Interconnection	37
In This Chapter	37
Axial/MX Interconnection	38
Power Connection	38
Edit Display Monitor Connection	38
Ethernet Connection	39
Control Panel Connection	39
Reference Video Connection	40
Printer Connection	41
PC Keyboard and Mouse Connection	42
Connecting Axial/MX into your Edit Environment	43
Comms Port Connections	43
Live Video Connections	44
Connections using Video Switcher AUX Busses	45
Connections using a Video Router (Matrix)	46
Connections using Alternate Video Feed Options	47
Video Preview Switching Methods	47
Video Switcher Preview Bus / Aux Bus	48
Video Router (Matrix)	48
Record Machine EE	48

External Preview Switcher	48
Audio Preview Switching Methods	49
Audio Mixer Preview Bus	49
Record Machine EE	49
External Preview Switcher	49
Audio Router (Matrix)	50
Pre-read Preview and Record Pass Monitoring	50
System Power Up and Status	51
Prerequisites	51
System Power Up	51
System Status	52
Display Chassis Status	52
Comms Chassis Status	52
System Reboot	53
Chapter 5 Engineering Specifications	55
In This Chapter	55
Comms Chassis Device Control	56
Display Chassis General Interface	56
Comms Chassis General Interface	56
Display Chassis Video I/O	57
Reference Video	57
Display Chassis Physical and Electrical	57
Comms Chassis Physical and Electrical	58
Control Panel Physical and Electrical	58
Index	59

1. Introduction

In This Guide

The following topics are covered in this chapter:

- [Installation Guide Introduction](#)
- [How to Use This Guide](#)
- [Terms and Conventions](#)
- [Contacting Accom](#)
- [System Overview](#)

Installation Guide Introduction

This guide gives an installation overview of the Accom Axial/MX On-Line Editing System. It provides the information necessary for installation within your edit environment, including all equipment interconnections.

The following chapters provide instructions for all aspects of Axial/MX installation:

- This chapter, “[Introduction](#)” describes how to use this guide, and provides a complete system overview.
- Chapter 2, “[Installation](#)” provides details on system power, cooling and airflow, site preparation and physical installation. Diagrams are provided for each chassis.
- Chapter 3, “[System Connectors](#)” provides information on all Axial/MX rear panel connectors and includes connector location and pinout diagrams.
- Chapter 4, “[System Interconnection](#)” outlines the procedures required to connect Ethernet, control panel, display monitor, reference video, source and peripheral devices, preview switching and pre-read monitoring.
- Chapter 5, “[Engineering Specifications](#)” provides detailed tables of Axial/MX specifications.

Important

Do not install any other software on your Windows® NT based Axial editor, other than that provided by Accom.

How to Use This Guide

Following are several important tips for streamlining your use of this guide in its electronic form — as an Acrobat PDF file.

Navigating and Searching

Use the bookmarks on the left side of Acrobat Reader to navigate to the desired location. All chapter files have the same bookmark structure for instant navigation to any section of the guide. In addition:

- Extensive hyperlinks are provided within the chapters for navigational ease.
- Use Acrobat’s “**Go to Previous View**” and “**Return to Next View**” buttons to trace your complete navigational path across files.
- Use the “**Previous Page**” and “**Next Page**” buttons to go to the previous or next page within the current file.
- As required, use Acrobat’s On-Line Help file to familiarize yourself with all of Acrobat’s navigational features.
- Acrobat provides incredible search capabilities. You can use the “**Find**” tool to search for words in the currently open file, or use the “**Search Index**” tool to perform a complete search of all chapter files. Please use Acrobat’s On-Line Help file to learn more about search functionality.

Table of Contents and Index

Use the **Table of Contents** bookmarks to navigate to the desired topic. Click any item to instantly jump to that section of the User’s Guide. Use the **Index** to jump to specific topics within any chapter. Each page number in the **Index** is a hyperlink.

Terms and Conventions

The following documentation conventions are used throughout this guide:

- The symbol ■ denotes an operations procedure, or marks the heading for a group of functions.
- The symbol ▲ denotes an example.
- Entries written in bold-face capital letters denote Control Panel buttons. For example: In the commands list, use **PREV** or **NEXT** to highlight a command.
- When two buttons together are required for an operation or function, the plus (+) sign is used between the buttons. This procedure requires that the operator hold down the first button, then press the second.

▲ **SHIFT + A-1** (hold down **SHIFT**, then press **A-1**)

- Softkey labels on the **User Menu** are shown in bold upper and lowercase letters between braces.

▲ Press **{SaveAs}** to ...

- A long string of entries between brackets “[]” denotes the syntax for using a function, with commas (,) separating each step. To follow the procedure, press the first button, release, press the second button, and so on. Within an entry string, the symbol “#” denotes entering a timecode or frame value.

▲ **[CUT, AUX 1-9, #, ENTER]**

- When the label “SOURCE” or “SRC” is included in a procedure, it instructs you to press the desired source button such as **SRC A** or **SRC B**. However, if the source is already selected, the source button need not be pressed again.

▲ In the operation **[SOURCE, #, SPEED]**, if **SRC E** is already selected in the Workspace, simply press **[#, SPEED]**.

The following documentation terms are used throughout this guide:

- “System” and “Edit System” refer to the Axial/MX Editing System.
- “Operator” and “Editor” refer to the person who uses the System.
- “Screen” and “Edit Screen” both refer to the Menu Monitor.
- “User Menu” refers to the small screen on the right side of the Control Panel.
- “Image” and “Picture” refer to video images on the Edit Screen.

The following check boxes appear if a System Option is required for a function to operate:

- Live Video Option** — Function requires the Live Video Option.
- RAVE Option** — Function requires the RAVE Option (requires the Live Video Option).
- ShowCase Option** — Function requires the ShowCase Option (requires the Live Video and RAVE options).

Contacting Accom

Axial Technical Support

- Phone: (650) 328-3818
- E-mail: techsupport@accom.com

World Wide Web

- Accom home page: <http://www.accom.com>
- From the home page, you can access the FTP site to download documents and Axial specfiles.
- Axial Forum at Editsuite.com — Online Resources for Post Production Editors: <http://www.editsuite.com>

Axial Specfile Resources

Visit the Accom FTP site, accessed from the Accom home page, to view and download Axial device specfiles. All device specfiles on the Accom web site are public domain and therefore have no charge.

Other sites such as “**Editsuite.com**” also have specfiles, some of which have not been checked by Accom, but are noted as such.

Accom will continue to write and provide specfiles and updates for all current and future Accom products. However Accom DOES NOT write or provide specfiles for other manufacturer’s equipment. Specfile help is available on the Accom website. In addition, Accom can put you in contact with freelance specfile writers, but note that all services will be between said freelancer and the customer.

System Overview

This section provides an overview of the complete Axial/MX system, including:

- [System Diagram](#)
- [Physical Components](#)
- [External Communication](#)
- [Video I/O](#)
- [Data Storage and Transfer](#)
- [Maintenance](#)

System Diagram

The Axial/MX system consists of a Display Chassis, Comms Chassis, Control Panel, high-resolution Display Monitor (customer supplied), and a Maintenance Keyboard and Mouse. The figure below illustrates a simplified block diagram of the system.

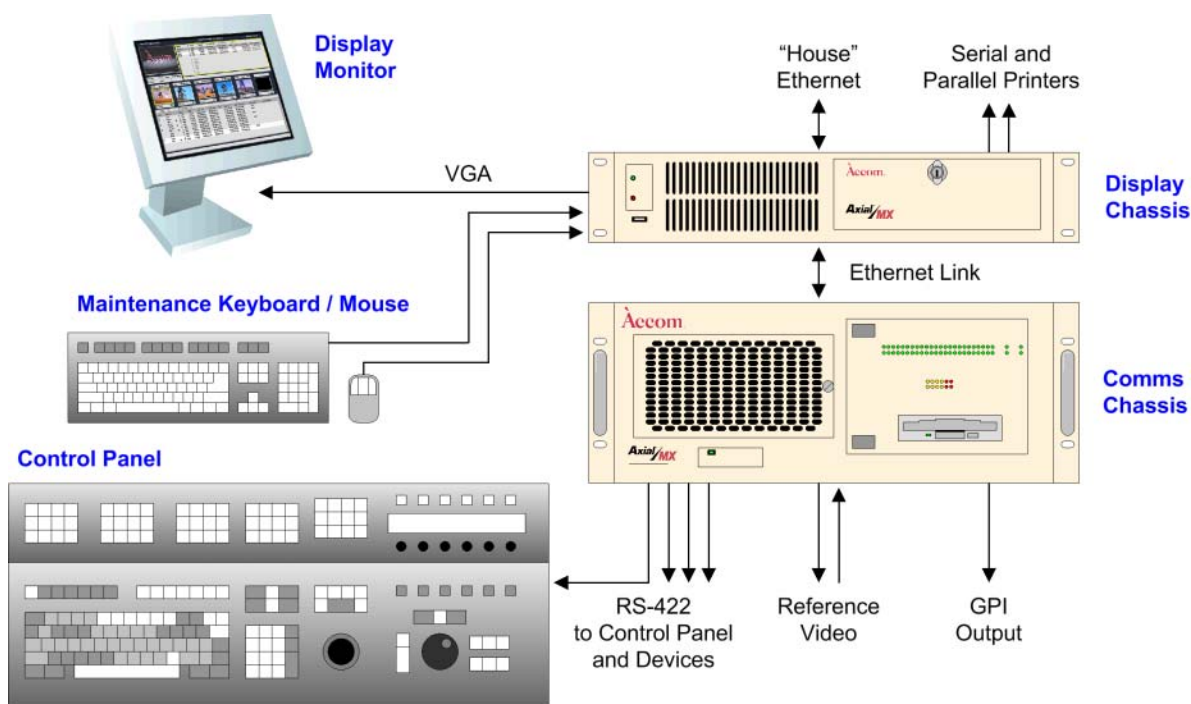

Figure 1-1. Axial System Diagram

Please note the following important points about system interconnection:

- The **Display Chassis** and **Comms Chassis** are linked with a dedicated 100BaseT Ethernet connection. An Ethernet "crossover" cable is required.
- The **Control Panel** connects to the **Comms Chassis** via an RS-422 serial connection.

- The **Display Chassis** includes a standard VGA output to connect the **Display Monitor**.
- The **Comms Chassis** requires reference video and RS-422 connections to all VTRs, DDRs, video switchers, audio mixers, DVEs, routers, and other peripheral devices.
- Additional communications ports include GPI Outputs, Ethernet, and Serial and Parallel Printers.

Recommendations

- ▲ Installing the Display Chassis in the edit suite is recommended for easy access to system drives and to minimize display, keyboard, and mouse cable runs. However, if desired, the Display Chassis may be located in the machine room.
- ▲ Installing the Comms Chassis in the machine room is recommended for easy access to serial device control lines.

System Processing

The Axial/MX system is powered by high-speed Pentium Processors. Additional processors are dedicated to device communication tasks for each serial port.

Video Line Standard Operations

The system line standard is switchable between 59.94i, 50i, 24p (option) and Auto Detect. Proper reference signals must be connected, and AC power selector switches on both the Display Chassis and Comms Chassis must be set to the proper line voltage.

Reference standard selection is performed by setting an initialization parameter in the Axial editing software and rebooting the system.

Important

In Appendix A of the Axial/MX User's Guide, refer to the "Miscellaneous" section for details on setting the **Reference Standard** initialization value.

Physical Components

The Axial/MX system consists of the following physical components:

- [Main Chassis Architecture](#)
- [Control Panel](#)
- [Display Monitor](#) (customer supplied)
- [Maintenance Keyboard and Mouse](#)
- [System Options](#)

Main Chassis Architecture

Axial/MX is based on a two-chassis architecture: a **Display Chassis** and a **Comms Chassis**. The Display Chassis and Comms Chassis communicate to each other via a

“private” Ethernet link.

- The **Display Chassis** runs under the Windows NT operating system and displays the editing application software. Its hard drive stores the Windows operating system, all session files and all EDLs.
- The **Comms Chassis** runs under the VxWorks operating system and drives the serial device communications.

Control Panel

Axial/MX includes a standard Axial Control Panel (this panel can also be used or swapped with **Axial 2010**, **Axial 2020** and **Axial 3000** systems). An external AC power supply is included with the Control Panel.

Display Monitor

The basic Axial/MX system **DOES NOT** include a Display Monitor. The Display Monitor used with Axial/MX must support 1280 x 1024 resolution, and greater than 32,000 colors. For CRTs, a 21-inch monitor with .25 mm pitch is recommended for optimum viewing, though smaller monitors with larger pitch may be used with the system. LCD (flat panel) monitors are also ideal.

Currently, the following monitors have been qualified for use with Axial/MX:

- NEC LCD1700V (Flatscreen)
- ViewSonic P810
- ViewSonic 20PS
- ViewSonic 21PS

Maintenance Keyboard and Mouse

Axial/MX includes a standard QWERTY PC Keyboard and PC Mouse for maintenance purposes. Display Chassis access to the PC Keyboard and Mouse is required when updating system software and for diagnostic maintenance, but is not typically needed during normal Axial/MX operation. Comms Chassis access to the PC Keyboard is required only for diagnostic maintenance. A separate PC Keyboard for the Comms Chassis is not included with the system.

System Options

All Axial/MX system options may be configured with initial system delivery or added at a later date. All options are field upgradable.

- **Hardware Options:** (plug-in hardware upgrade board sets)
 - ~ Live Video (requires a software key)
 - ~ Extra Comms Ports

- **Software Options:** (software key-based)
 - ~ RAVE™
 - ~ ShowCase™
 - ~ 24P

External Communication

Axial/MX offers a complete array of external communications ports. This section discusses the following communications parameters:

- **Device Control**
 - ~ [Comms Port Communications](#)
 - ~ [GPI Outputs](#)
- **General Interface**
 - ~ [Display Chassis to Comms Chassis Link](#)
 - ~ [Control Panel Port](#)
 - ~ [Display Monitor](#)
 - ~ [Printer](#)
 - ~ [Ethernet](#)

Comms Port Communications

- 12 RS-422 Comms Ports are standard
- 12 additional RS-422 Comms Ports may be added as an option (for a maximum total of 24 ports)

Comms Chassis connections

Using the RS-422 serial comms ports, the Axial Editor communicates to devices via their Remote, Auxiliary, or Editor serial port. Each Axial RS-422 serial comms port is configured for the desired device interface and protocol using the **Assign Manager Window**, as access via the **ASIGN MNGR** button on the Axial Control Panel.

Important

In Chapter 3, “System Configuration” of the Axial/MX User’s Guide, refer to the “**Device Configuration**” section for full details on machine assignment.

Setup configurations of devices and peripherals are stored on disk. These setups provide a default boot-up configuration, and also permit the editor to quickly change configurations from session to session.

Note

Axial/MX does not support RS-232 serial device communications. Also, Axial/MX hardware does not include RS-422 serial loop-through connections (e.g., separate loop-in and loop-out connectors).

GPI Outputs

- 12 GPI Outputs are standard
- 12 additional GPI Outputs may be added as part of the Extra Comms Ports option (for a maximum total of 24 GPI Outputs)

Display Chassis to Comms Chassis Link

- 100BaseT / RJ-45 “private” Ethernet link is used for communication between the two chassis. An Ethernet “crossover” cable is required.

Control Panel Port

- RS-422 communications between chassis and Axial Control Panel

Display Monitor

- Standard VGA output — 15-pin D connector

Printer

- Serial and Parallel printers supported

Ethernet

- TCP/IP link to other Axial (2010, 2020, 3000 or MX) systems or “house” Ethernet devices on your facility LAN
- 1000BaseT (gigabit) / 100BaseT supported

Video I/O

Following are the Video I/O requirements for Axial/MX:

- **Reference Video**
 - ~ Composite video (color black) input is required.
 - ~ Reference selection may be “hard” set to NTSC, PAL, 24p biphase (optional), or set to auto-detect NTSC or PAL.
- **Live Video Option**
 - ~ Four assignable SDI video inputs plus one serial digital reference video input are provided on the video input card. Input assignments are performed using the **Assign Manager Window**.
 - ~ If desired, external video switcher aux busses or video router outputs can be used to route video sources to the source windows.

Data Storage and Transfer

The Axial/MX Display Chassis includes:

- **Hard Drive**
 - ~ High-capacity primary system drive
- **3.5" Floppy Drive**
 - ~ EDL import / export and saving setup information
 - ~ Specfile updates
 - ~ DOS and RT-11 supported
- **CD-ROM Drive**
 - ~ Standard media for software updates
 - ~ Not to be used as a “cup holder”

Note

Axial/MX does not support optical or floptical drives. A **ZIP drive** (customer supplied) may be connected to the Display Chassis' parallel port.

Maintenance

Axial/MX includes maintenance features for each chassis:

- **Display Chassis Maintenance**
 - ~ Required for updating system software and for diagnostic maintenance.
 - ~ Standard VGA monitor required (Axial Display Monitor may typically be used).
 - ~ Standard QWERTY PC keyboard required (supplied with Axial/MX Base System).
 - ~ Standard PC mouse recommended (supplied with Axial/MX Base System).
- **Comms Chassis Maintenance**
 - ~ Required for diagnostic maintenance.
 - ~ Standard VGA monitor is required (not included with Axial/MX Base System).
 - ~ Standard QWERTY PC keyboard required (not included with Axial/MX Base System, although the Display Chassis' PC Keyboard may be used).
 - ~ 3.5" floppy drive included for maintenance purposes.



2. Installation

In This Chapter

This chapter provides details on system power, cooling and airflow, site preparation, and physical installation. The following topics are discussed:

- [Safety Precautions](#)
- [Unpacking and Inspection](#)
- [Power Consumption](#)
- [Cooling and Airflow](#)
- [Site Preparation](#)
- [Physical Installation](#)
- [Software Installation](#)

Safety Precautions

For all Axial/MX installation procedures, observe the following important safety and handling rules to avoid damage to yourself and the equipment:

Important

Note the following important points regarding AC:

- To protect users from electric shock, ensure that the chassis power supplies connect to earth via the ground wire provided in the AC power Cord.
- The AC Socket-outlet should be installed near the equipment and be easily accessible.

Important

When handling any internal chassis boards or components, please observe the following important safety precautions:

- Perform the system installation in an anti-static environment.
- Always stand on an anti-static mat, not carpet.
- Ground yourself to the chassis, by touching it, just before handling internal boards and mechanisms.
- Hold a board by its edges. Do not touch the components on the board.

Unpacking and Inspection

Before opening the boxes, inspect them for damage. If you find any damage, notify the shipping carrier immediately for all claims adjustments. Your Axial/MX editing system comes in two boxes. As you open each box, compare its contents against the packing slips. If you find any shortages contact your Accom sales representative.

Once you have removed all the components from their packaging and checked that all the listed components are present, visually inspect the **Display Chassis**, **Comms Chassis** and **Control Panel** to ensure there was no damage during shipping. If there is damage, notify the shipping carrier immediately for all claims adjustments.

System Option Keycode Sheet

Each Axial/MX shipment includes a **System Option Key Code Sheet**. This sheet lists your system's hardware serial numbers, hardware ID number and unique option keycode. When you unpack your system, locate the sheet and store it in a safe place. It will be required if you reinstall or upgrade software, swap a chassis or install new options.

Shipping Brackets

Both the **Display Chassis** and **Comms Chassis** are installed with a main card cage Shipping Bracket to securely hold the cards in their slots and prevent them from being displaced during shipment.

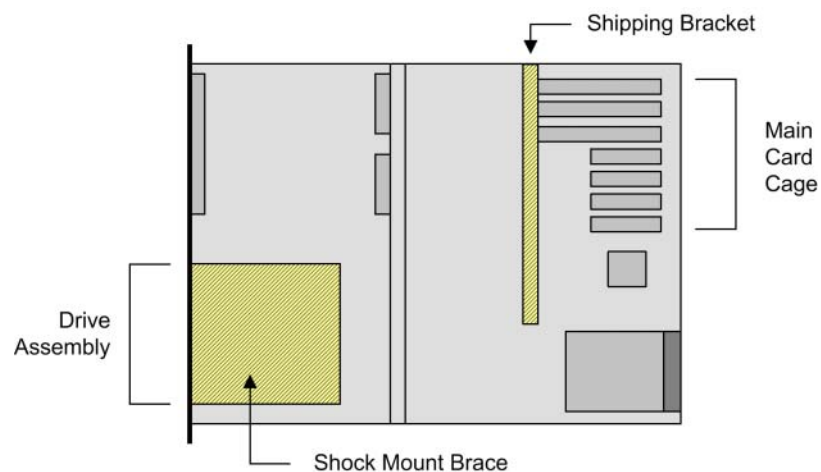

Figure 2-1. Chassis Shipping Bracket and Shock Mount Brace

In addition, each chassis includes a drive assembly Shock Mount Brace to prevent system drives from being damaged during shipment. Please note the following important points regarding the shipping bracket and shock mount brace:

- The shipping bracket may remain installed in each chassis during normal operation. You may remove the Shipping Brackets if desired, but they must be reinstalled prior to shipping.

2. Installation

Power Consumption

- For optimum drive operation, remove the Shock Mount Brace from each chassis to enable the shock absorbing system to absorb motion effectively. The Shock Mount Braces must be reinstalled prior to shipping.

Power Consumption

The following topics are discussed:

- [Chassis](#)
- [Control Panel](#)

Chassis

The Axial/MX **Display Chassis** and **Comms Chassis** each draw less than 250 watts from an input range of 90-132/180-264 VAC, 47-63 Hz (voltage selector slide switch). Standard 15A/110 VAC or 10A/240 VAC power service is recommended.

Important

Use the **Voltage Selector Slide Switch** on the rear of the chassis to ensure that the Axial/MX Display Chassis and Comms Chassis are set to the proper line voltage either 115 or 230 VAC.

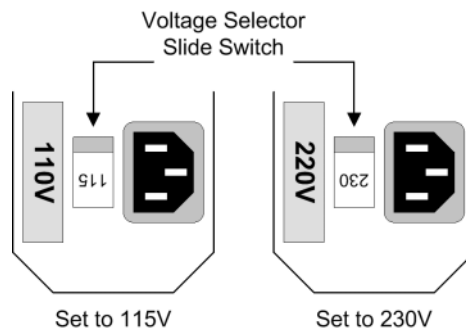

Figure 2-2. Voltage Selection

Control Panel

The Axial/MX Control Panel draws less than 42 watts for an input range of 90-264 VAC, 47-63 Hz (auto select). The panel receives DC power from an external power supply. Standard 15A/110 VAC or 10A/240 VAC power service is recommended.

Cooling and Airflow

The Axial/MX **Display Chassis** and **Comms Chassis** are forced air-cooled. Using two low noise fans mounted mid-chassis, air is drawn in through the front panel of the chassis and forced into the main card cage. It exhausts through slotted vents at the rear of the side and top panels. The Pentium Processor in each chassis has its own cooling fan mounted on the IC. The Power Supply also has its own cooling fan.

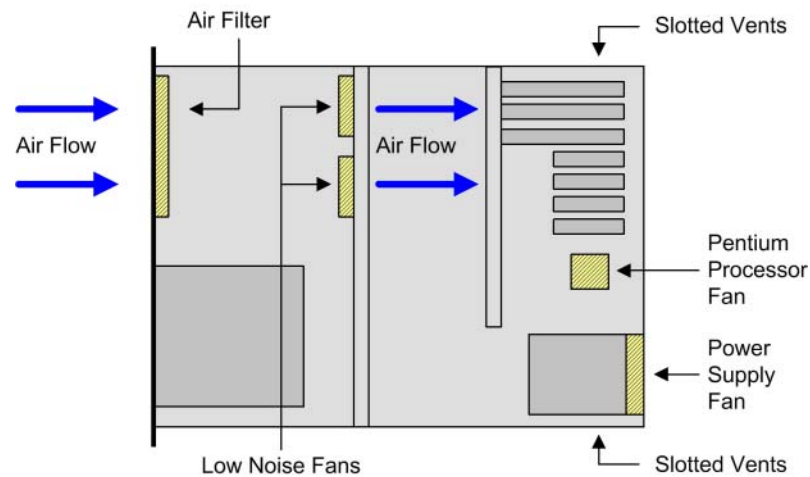

Figure 2-3. Axial/MX Chassis Airflow

Each chassis has a front-panel air filter:

- On the front of the **Comms Chassis** is a vented door that secures a removable air filter.
- On the front of the **Display Chassis** is a locking door that provides access to the air filter.

To avoid overheating and subsequent damage to each chassis, ensure that the filter is always in place and that there is no restriction to the front/rear airflow. For proper ventilation, one rack unit (minimum) of empty space above an Axial/MX chassis is recommended.

Note

The air filter should be cleaned or replaced every three months.

The Axial **Control Panel** is conduction air-cooled. Air ventilates via slotted panels along the top edge and the left side of the rear panel (viewed from the front of the Control Panel). A minimum of six inches ventilation space should be maintained between the rear side of the Control Panel and a console enclosure.

Site Preparation

The environment in which you install your Axial/MX system should be clean, properly lit, free from static, and have adequate power, ventilation, and space for all components. Installing the **Display Chassis** in the edit suite is recommended for easy access to system drives and to minimize display, keyboard, and mouse cable runs (as shown below). However, if desired, the Display Chassis may be located in the machine room. Installing the **Comms Chassis** in the machine room is recommended for easy access to serial device control lines.

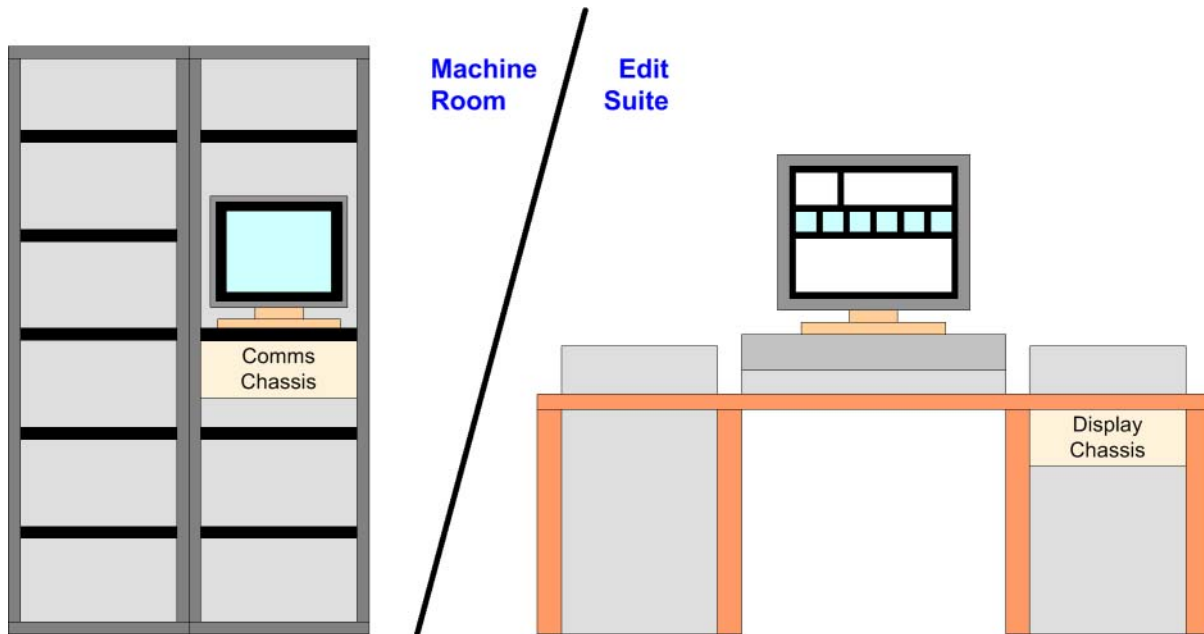

Figure 2-4. Sample Equipment Configuration

Tips

Please note:

- To minimize movement in the edit suite, the Axial/MX Control Panel should be placed on the right side of the video switcher.
- For increased flexibility in the edit suite, you may configure your system with an infrared PC keyboard and RF mouse (these may be purchased from a computer retailer).

Physical Installation

The following topics are discussed in this chapter:

- [Display Chassis Rack Mounting](#)
- [Comms Chassis Rack Mounting](#)
- [Control Panel Mounting](#)

Display Chassis Rack Mounting

The **Display Chassis** dimensions are:

- 3.5 High (8.89 cm), 2 RU
- 17.0 Wide (43.18 cm)
- 18.5 Deep (46.99 cm)

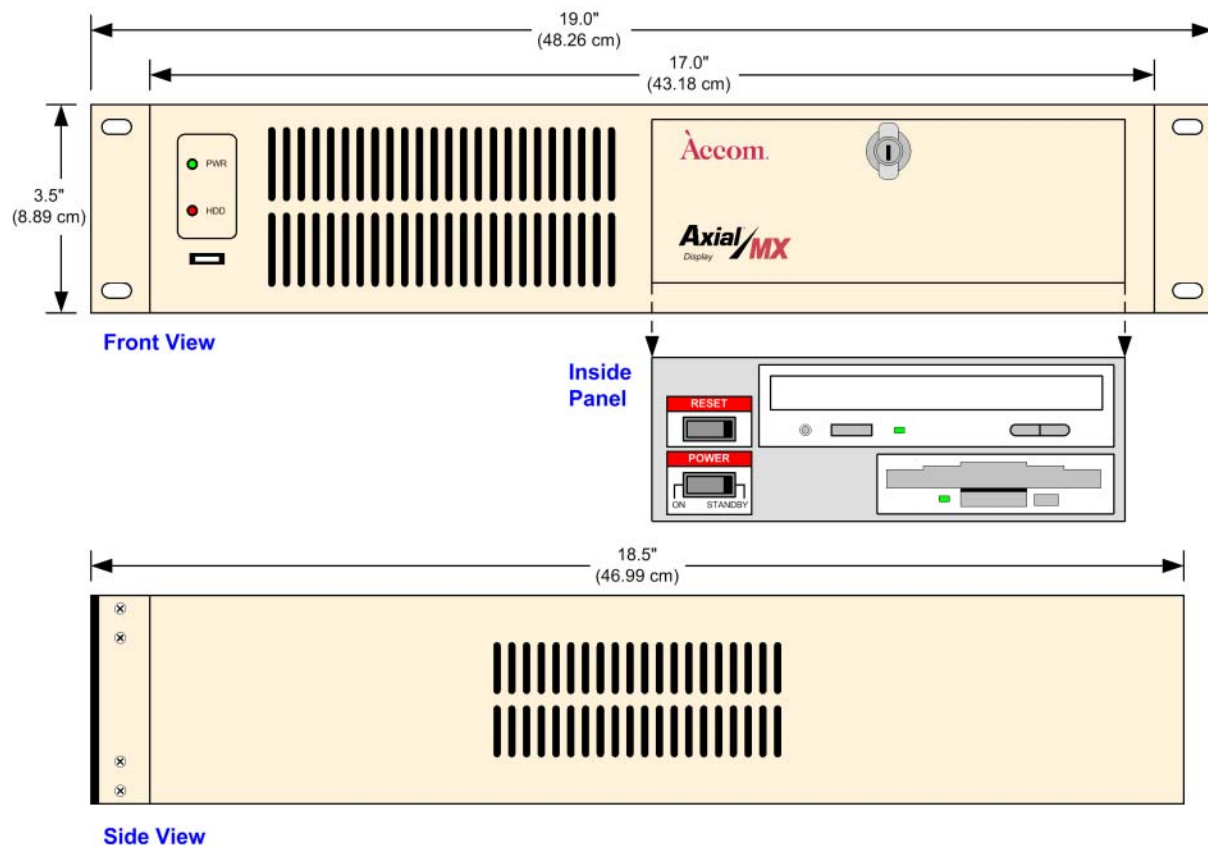

Figure 2-5. Display Chassis Dimensions

Please note:

- The front panel s USB port is currently not implemented.

2. Installation

Physical Installation

- The inside panel includes a **STANDBY POWER** switch (leave in the ON position) and a **RESET** switch.
- The floppy drive is used for importing and exporting EDLs and other files.
- The CD-ROM drive is used for system software updates.

The Display Chassis is designed to be installed in a standard 19 rack. Use the figure below for reference during the **Display Chassis** rack mount procedure:

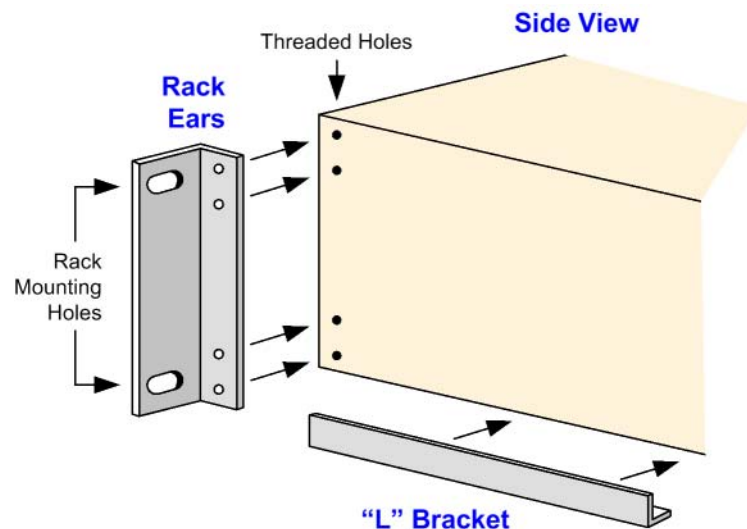

Figure 2-6. Display Chassis Rack Mount Detail

■ Use the following procedure to rack mount the Display Chassis:

1. Determine a location in the destination rack (in your Edit Suite or Machine Room) that has adequate ventilation with no restriction to the chassis front-to-rear air flow.
2. Using the supplied rack mounting kit (that includes Rack Ears, L Brackets and screws), attach each **Rack Ear** to the front of the Display Chassis. Threaded holes are provided in the side of the chassis. Use the illustration above for reference.
3. Install the supplied **L Brackets** in your rack. These two brackets are designed to carry the weight of the chassis, but they do not attach to the chassis itself. The bottom of the chassis rests on the brackets.
4. Using four rack screws (not supplied), rack mount the chassis. Rack threads may be metric or otherwise, depending upon the rack type.

Important

On each side, install the *lower* of the two mounting holes first. Once complete, install the upper of the two holes.

Comms Chassis Rack Mounting

The **Comms Chassis** dimensions are:

- 7.0 High (17.78 cm), 4 RU
- 17.0 Wide (43.18 cm)
- 24.5 Deep (62.23 cm)

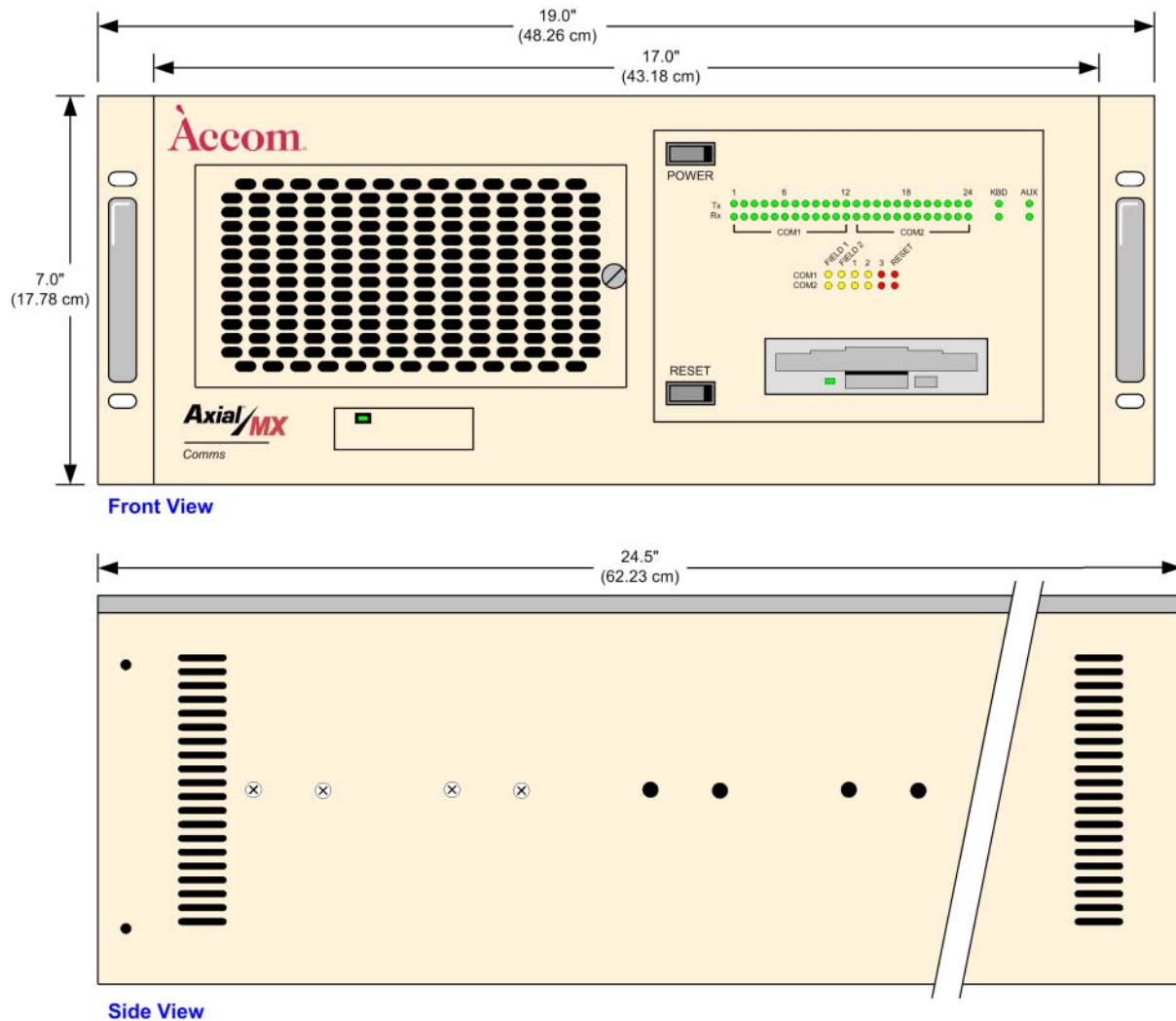

Figure 2-7. Comms Chassis Dimensions

Please note:

- The Comms Chassis is designed to be installed in a standard 19 rack. The rack mount kit enables you to install the chassis in a rack up to 30 deep.
- The floppy drive on the front panel is used only for maintenance software updates and other engineering functionality. It is not used for EDLs.
- In Chapter 4, refer to the [Comms Chassis Status](#) section for details on front panel status LEDs.

2. Installation

Physical Installation

Use the figure below for reference during the **Comms Chassis** rack mount procedure:

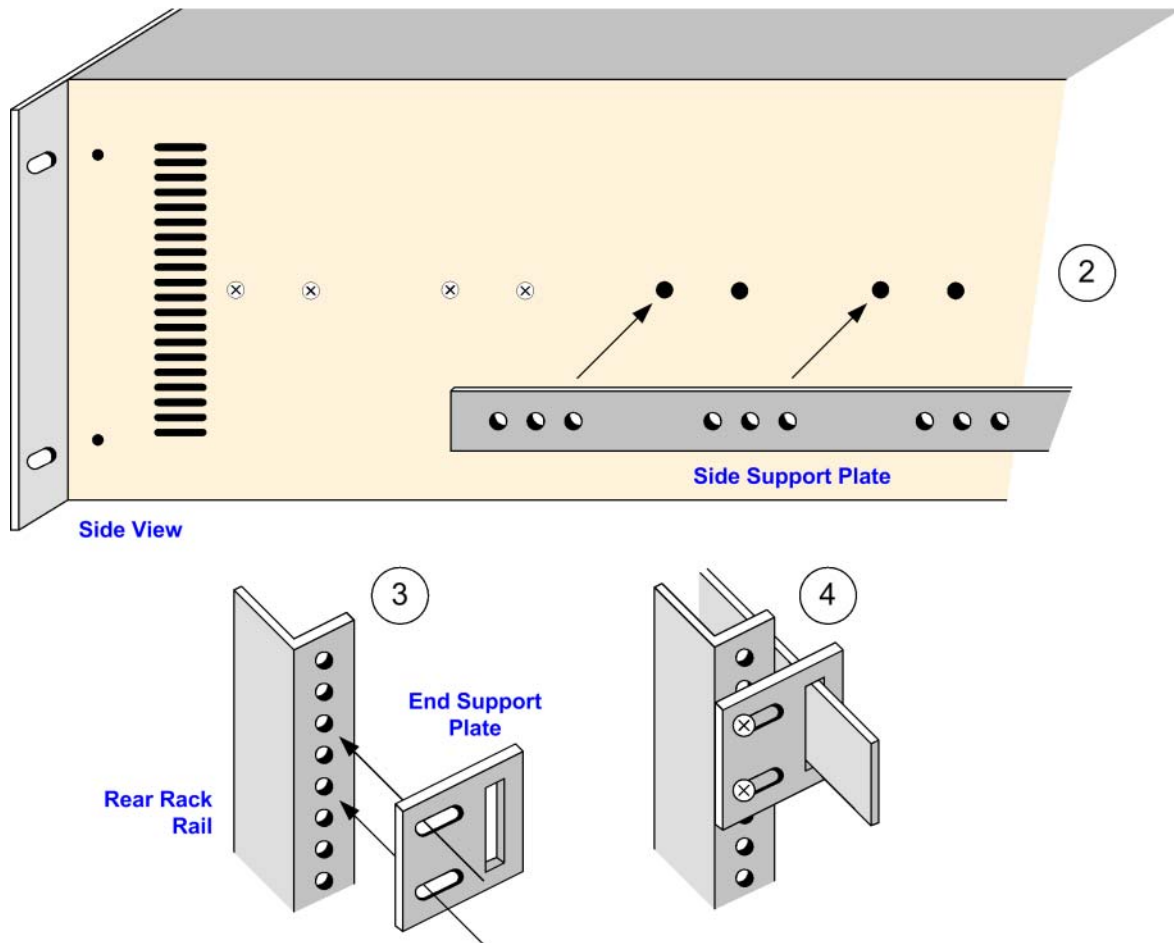

Figure 2-8. Comms Chassis Rack Mount Detail

- Use the following procedure to rack mount the Comms Chassis:
 1. Determine a location in the target rack (in the Machine Room) that has adequate ventilation with no restriction to the chassis air flow.
 2. In the rack, measure the distance between the front and rear rails. Use this measurement to determine the best position for the **Side Support Plate** to attach to the chassis so that the Plate extends beyond the rear rail a minimum of 1 inch (2.54 cm). Attach both Plates as shown above.
 3. Attach the two **End Support Plates** to the rear rails as shown above. Make sure the chassis will be level when the installation is complete.
 4. Place the Comms Chassis in position in the rack, and carefully slide the **Side Support Plates** through the slots in the **End Support Plates**.
 5. Install the chassis into the rack, and secure the front with screws in the front ears of the chassis.

An alternative is to mount the **Comms Chassis** with rack slides. This allows you to access the internal electronics from the top of the chassis without removing the unit from the rack.

Note

Accom does not supply rack slides.

Control Panel Mounting

Supports with rubber feet screw on the bottom of the Control Panel allowing it to sit directly on a desk. Alternately you can cut a hole in the desk and surface mount the Control Panel. The figure below shows the Control Panel dimensions.

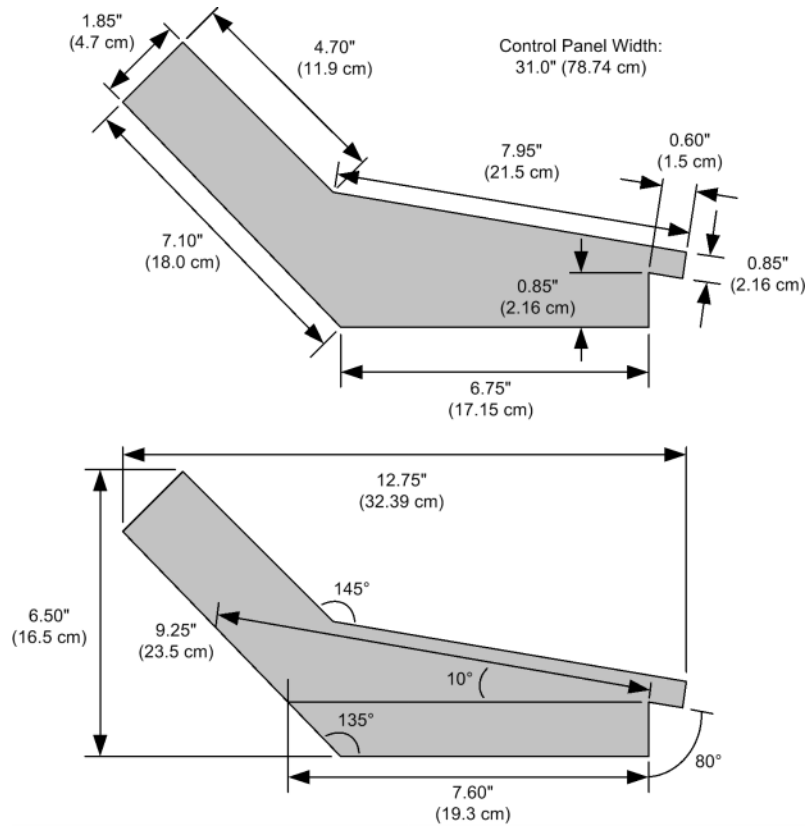

Figure 2-9. Control Panel Dimensions

Note that the Control Panel cannot be more than 3000 feet (1000 meters) from the Comms Chassis.

2. Installation

Software Installation

Control Panel External Power Supply

The External Power Supply must be located within six feet of the Control Panel. Dimensions are listed below:

- 2.5 High (6.4 cm)
- 3.75 Wide (9.5 cm)
- 6.5 Deep (16.5 cm)

Software Installation

As required, new software may be provided by Accom for updates and various system options. Complete software installation instructions will be provided with each specific release, in the Release Notes that accompany the software CD-ROM.

Important

Do not install any other software on your Windows[®] NT based Axial editor, other than that provided by Accom.

3. System Connectors

In This Chapter

This chapter provides information on all Axial/MX rear panel connectors, including connector location and pin-out diagrams.

The following topics are discussed:

- [Display Chassis Rear Panel Connectors](#)
- [Comms Chassis Rear Panel Connectors](#)
- [Display Chassis Front Panel Connectors](#)
- [Control Panel Connections](#)
- [Connector Pinouts](#)

3. System Connectors

Display Chassis Rear Panel Connectors

Display Chassis Rear Panel Connectors

The figure below illustrates the **Display Chassis** rear panel:

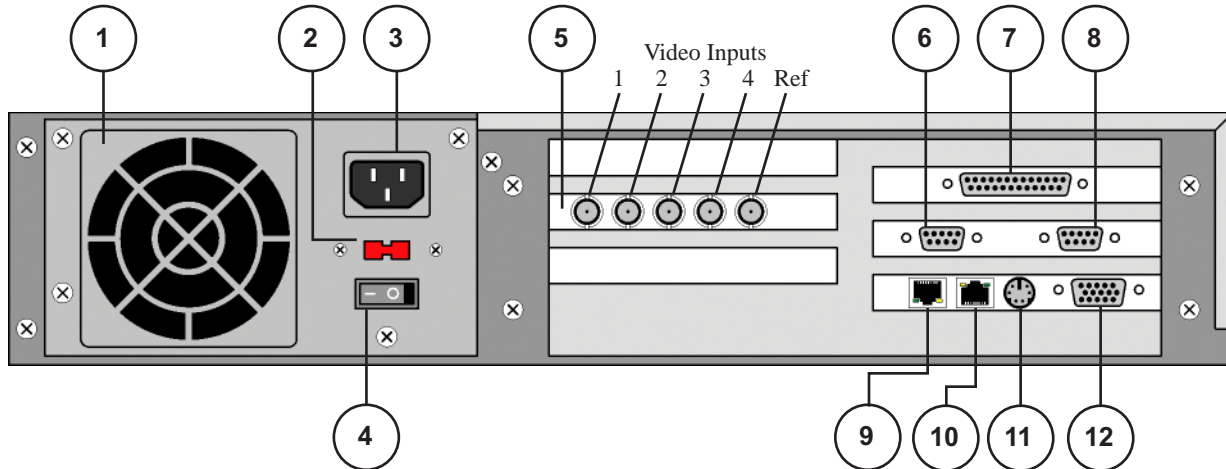

Figure 3-1. Display Chassis Rear Panel Connectors

1) Exhaust Fan	5) Video Inputs (Live Video Option)	9) Ethernet Port (Private)
2) Voltage Selector	6) Com 2	10) Ethernet Port (House LAN)
3) AC Power	7) Parallel Printer Port	11) Keyboard/Mouse Port
4) Main Power Switch	8) Com 1	12) VGA Display Monitor

Following are descriptions of each rear panel control and connector:

1) Exhaust Fan

The **Exhaust Fan** pulls air thru the chassis, from the front air vents. To prevent overheating, do not block the exhaust fan.

2) Voltage Selector

The **Voltage Selector** is used to set to the proper line voltage — either 115 or 230 VAC. In Chapter 2, refer to the “[Chassis](#)” section for details.

3) AC Power

Use the **AC Power** connector to connect the chassis to your facility’s AC power source.

4) Main Power Switch

The **Main Power Switch** turns the power supply on. Once on, use the front panel “Power” toggle to power up the chassis.

5) Video Inputs (Live Video Option)

(BNC) Four assignable SDI (SD/HD) video inputs are provided for the Master and Source windows on the Axial/MX display monitor. A serial digital reference video input is also provided.

6) Com 2

This port is not functional.

7) Parallel Printer Port

(25-pin D female) Parallel printer port allowing connection to an external printer. Refer to the "[Parallel Printer Connector](#)" section for pinouts.

Note

A **ZIP Drive** that uses a parallel interface can be connected to the Parallel Printer Port

8) Com 1

(9-pin D female) Serial RS-232 port allowing connection to an external serial printer or other serial devices. Refer to the "[RS-232 Serial Connector](#)" section for pinouts.

9) Ethernet Port (Private)

(RJ-45 female) 100BaseT Ethernet link for communication with Axial/MX Comms Chassis. An Ethernet "crossover" cable is required. Refer to the "[Ethernet Connectors](#)" section for pinouts.

10) Ethernet Port (House LAN)

(RJ-45 female) Ethernet port for communication with other Axial Editors or "House" devices. 1000BaseT (gigabit) or 100BaseT supported. Refer to the "[Ethernet Connectors](#)" section for pinouts.

11) Keyboard/Mouse Port

(P/S 2 female) This port connects to the supplied "splitter" cable, enabling connection of a keyboard and mouse port for software installation purposes.

12) VGA Display Monitor

(15-pin D female) Display monitor output for the Axial/MX VGA (1280x1024) color monitor. Refer to the "[VGA Connectors](#)" section for pinouts.

3. System Connectors

Comms Chassis Rear Panel Connectors

Comms Chassis Rear Panel Connectors

The figure below illustrates the **Comms Chassis** rear panel:

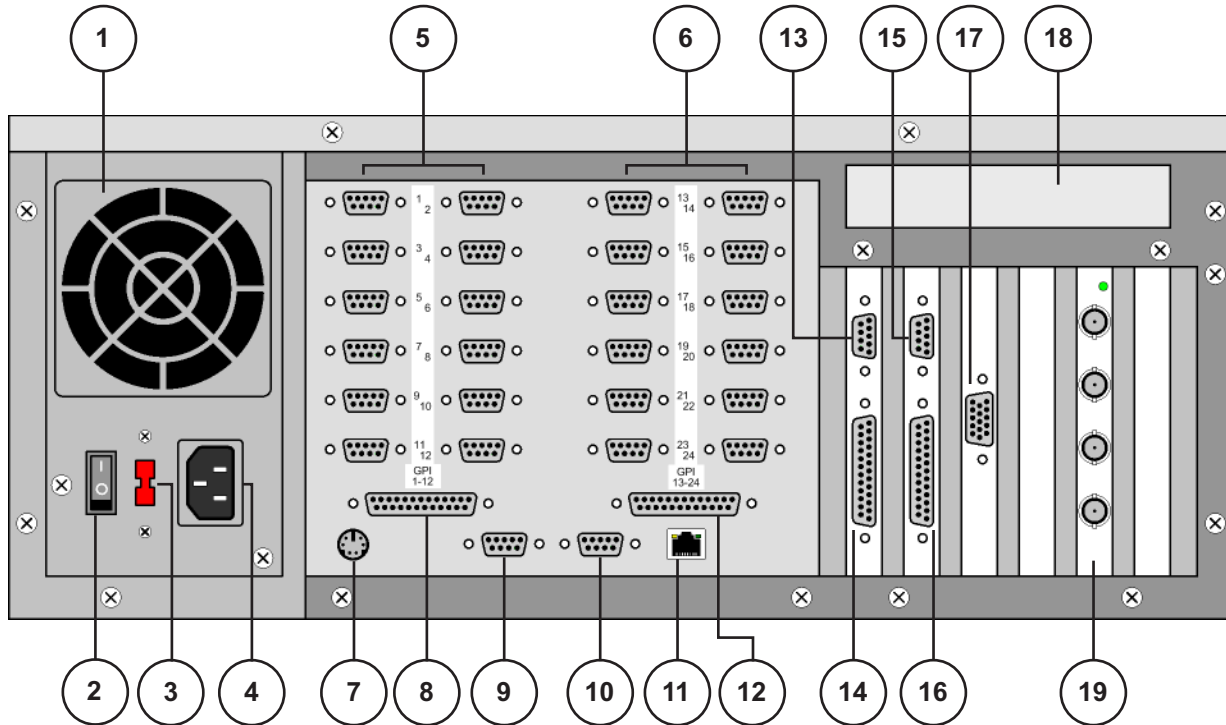

Figure 3-2. Comms Chassis Rear Panel Connectors

1) Exhaust Fan	8) GPI Connector 1	15) Auxiliary Com Port (Option)
2) Main Power Switch	9) Spare 1	16) Spare 4 (Option)
3) Voltage Selector	10) Spare 2 (Option)	17) VGA Display Monitor
4) AC Power	11) Ethernet Port (Private)	18) ID Label
5) Serial Device Ports 1-12	12) GPI Connector 2 (Option)	19) Reference Video Card
6) Serial Device Ports 13-24 (Option)	13) Control Panel Port	
7) Keyboard/Mouse Port	14) Spare 3	

Following are descriptions of each rear panel control and connector:

1) Exhaust Fan

The **Exhaust Fan** pulls air thru the chassis, from the front air vents. To prevent overheating, do not block the exhaust fan.

2) Main Power Switch

The **Main Power Switch** turns the power supply on. Once on, use the front panel “Power” toggle to power up the chassis.

3) Voltage Selector

The **Voltage Selector** is used to set to the proper line voltage — either 115 or 230 VAC. In Chapter 2, refer to the “[Chassis](#)” section for details.

4) AC Power

Use the **AC Power** connector to connect the chassis to your facility’s AC power source.

5) Serial Device Ports 1-12

(9-pin D female) **Ports 1-12** can be used to connect up to 12 RS-422 serial devices to Axial, and assign them via the **Assign Manager Window**. Refer to the “[RS-422 Connectors](#)” section for pinouts.

6) Serial Device Ports 13-24 (Option)

(9-pin D female) **Ports 13-24** can be used to connect up to 12 RS-422 serial devices to Axial, and assign them via the **Assign Manager Window**. These ports are optional and field upgradable. Refer to the “[RS-422 Connectors](#)” section for pinouts.

7) Keyboard/Mouse Port

(P/S 2 female) This port connects to the supplied “splitter” cable, enabling connection of a keyboard and mouse for maintenance purposes.

8) GPI Connector 1

(25-pin D female) Provides GPI outputs 1-12 for contact-closure device control. Refer to the “[GPI Connectors](#)” section for pinouts.

9) Spare 1

(9-pin D female) This connector is not used.

10) Spare 2 (Option)

(9-pin D female) This connector is not used.

11) Ethernet Port (Private)

(RJ-45 female) 100BaseT Ethernet link for communication with the Axial/MX Display Chassis. Refer to the “[Ethernet Connectors](#)” section for pinouts.

12) GPI Connector 2 (Option)

(25-pin D female) Provides GPI outputs 13-24 for additional contact-closure device control. This port is optional. Refer to the “[GPI Connectors](#)” section for pinouts.

13) Control Panel Port

(9-pin D female) Provides serial communications with the Axial/MX Control Panel. Refer to the “[RS-422 Connectors](#)” section for pinouts.

14) Spare 3

(25-pin D) This connector is not used.

3. System Connectors

Comms Chassis Rear Panel Connectors

15) Auxiliary Com Port (Option)

(9-pin D female) This port may be used as serial port #25. Refer to the “[RS-422 Connectors](#)” section for pinouts.

16) Spare 4 (Option)

(25-pin D) This connector is not used.

17) VGA Display Monitor

(15-pin D female) Display monitor output for the maintenance display. Refer to the “[VGA Connectors](#)” section for pinouts.

18) ID Label

The **ID Label** indicates the connector assignments for the cards immediately below the label.

19) Reference Video Card

(4 x BNC) This card provides 525/625 Reference Video input connectors. A composite video input signal (NTSC or PAL) is required to lock the system to house reference.

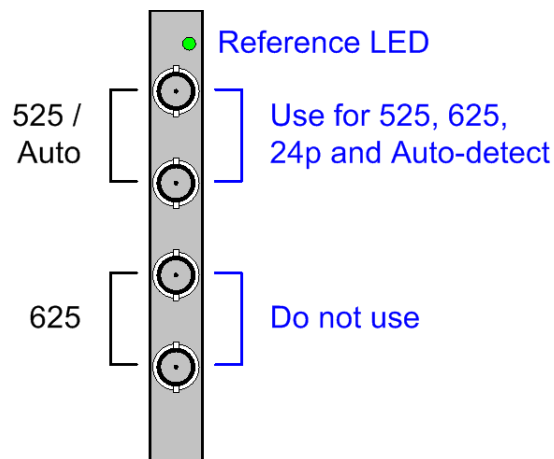

Figure 3-3. Reference Video Card

Note that the **Reference LED** lights solid when a valid 525 or 625 reference signal is present. When the system is running in 24p mode, the LED will blink.

Important

Even though both 525 and 625 connectors are provided, only use the top **525/AUTO** connector pair for 525, 625, 24P and “Auto” detect reference connection. In Chapter 4, refer to the “[Reference Video Connection](#)” section for instructions.

Display Chassis Front Panel Connectors

The **USB** port on the front panel of the **Display Chassis** is currently not implemented.

Control Panel Connections

At the center rear of the Control Panel is a recess with two connectors.

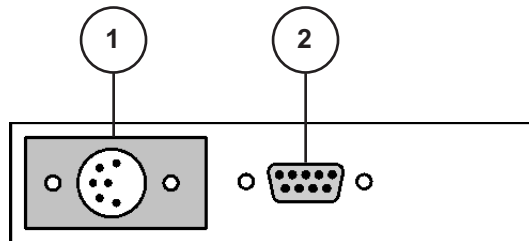

Figure 3-4. Control Panel Connectors

1) Power	2) Control Panel
--------------------------	----------------------------------

1) **Power**

(6-pin XLR) The **Power** connector provides DC power for the Control Panel.

2) **Control Panel**

(9-pin D female) The **Control Panel** connector provides RS-422 serial communications with the Comms Chassis.

3. System Connectors

Connector Pinouts

Connector Pinouts

This section provides pinout details for the Display Chassis and Comms Chassis rear panel connectors. The following connector diagrams are provided:

- [RS-422 Connectors](#)
- [GPI Connectors](#)
- [RS-232 Serial Connector](#)
- [Parallel Printer Connector](#)
- [Ethernet Connectors](#)
- [VGA Connectors](#)

RS-422 Connectors

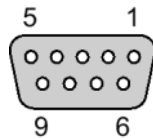

Figure 3-5. RS-422 Connector Pinout

This pinout configuration is used for:

- **Comms Chassis:** Device Control Ports 1-24
- **Comms Chassis:** Auxiliary Comms Port
- **Comms Chassis:** Control Panel Port

Table 3-1. RS-422 Connector Pinouts

Pin	Function
1	Chassis Ground
2	- Receive Data (Rx-)
3	+ Transmit Data (Tx+)
4	Signal ground
5	No connection
6	Signal Ground
7	+ Receive Data (Rx+)
8	- Transmit Data (Tx-)
9	Chassis Ground

GPI Connectors

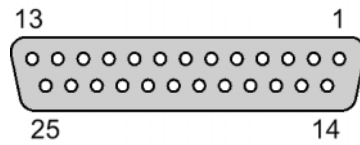

Figure 3-6. GPI Connector Pinout

This pinout configuration is used for:

- **Comms Chassis:** GPI Connectors 1 and 2

The GPI Outputs are relay closure type. The normal state of each GPI Output relay is open — when activated the GPI Output relay is closed.

Table 3-2. GPI Connector Pinouts

Pin	Function	Pin	Function
1	GPI OUT 1 +	14	GPI OUT 1 -
2	GPI OUT 2 +	15	GPI OUT 2 -
3	GPI OUT 3 +	16	GPI OUT 3 -
4	GPI OUT 4 +	17	GPI OUT 4 -
5	GPI OUT 5 +	18	GPI OUT 5 -
6	GPI OUT 6 +	19	GPI OUT 6 -
7	GPI OUT 7 +	20	GPI OUT 7 -
8	GPI OUT 8 +	21	GPI OUT 8 -
9	GPI OUT 9 +	22	GPI OUT 9 -
10	GPI OUT 10 +	23	GPI OUT 10 -
11	GPI OUT 11 +	24	GPI OUT 11 -
12	GPI OUT 12 +	25	GPI OUT 12 -
13	SIGNAL GROUND		

3. System Connectors

Connector Pinouts

RS-232 Serial Connector

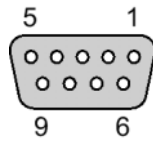

Figure 3-7. Serial Connector Pinout

This pinout configuration is used for:

- **Display Chassis:** Com 1

Table 3-3. Serial Connector Pinouts

Pin	Function
1	No connection
2	Receive Data (Rx)
3	Transmit Data (Tx)
4	No connection
5	Signal Ground
6	Signal Ground
7	Ready to Send (RTS)
8	Clear to Send (CTS)
9	No connection

Parallel Printer Connector

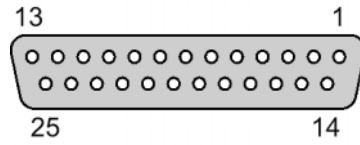

Figure 3-8. Parallel Printer Connector Pinout

This pinout configuration is used for:

- **Display Chassis:** Parallel Printer Port

Table 3-4. Parallel Printer Connector Pinouts

Pin	Function	Pin	Function
1	STB	14	Paper Feed
2	Data Bit 0	15	Error / Fault
3	Data Bit 1	16	Printer Init
4	Data Bit 2	17	Select
5	Data Bit 3	18	Ground
6	Data Bit 4	19	Ground
7	Data Bit 5	20	Ground
8	Data Bit 6	21	Ground
9	Data Bit 7	22	Ground
10	ACK	23	Ground
11	BSY	24	Ground
12	PE	25	Ground
13	SLCT		

Note

A **ZIP Drive** that uses a parallel interface can be connected to the Parallel Printer Port

Ethernet Connectors

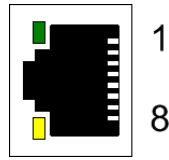

Figure 3-9. Ethernet Connector Pinouts

This pinout configuration is used for:

- **Display Chassis:** Ethernet Port (House LAN)
- **Display Chassis:** Ethernet Port (Private)
- **Comms Chassis:** Ethernet Port (Private)

Table 3-5. Ethernet Connector Pinouts

Pin	Function
1	+ Transmit Data (Tx+)
2	- Transmit Data (Tx-)
3	+ Receive Data (Rx+)
6	- Receive Data (Rx-)

Crossover Cable

A crossover RJ-45 cable must be used for the RJ-45 Ethernet connection between the Display Chassis and the Comms Chassis. These pin assignments are for the crossover RJ-45 cable.

Table 3-6. Ethernet Crossover Connector Pinouts

Pin	Function	Pin	Function
End 1		End 2	
1	+ Transmit Data (Tx+)	3	+ Receive Data (Rx+)
2	- Transmit Data (Tx-)	6	- Receive Data (Rx-)
3	+ Receive Data (Rx+)	1	+ Transmit Data (Tx+)
6	- Receive Data (Rx-)	2	- Transmit Data (Tx-)

VGA Connectors

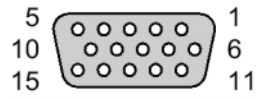

Figure 3-10. VGA Connector Pinouts

This pinout configuration is used for:

- **Display Chassis:** VGA Display Monitor Connector
- **Comms Chassis:** VGA Display Monitor Connector

Table 3-7. VGA Connector Pinouts

Pin	Function
1	Red Output
2	Green Output
3	Blue Output
4	No connection
5	Self Test
6	Red Return
7	Green Return
8	Blue Return
9	No connection
10	Digital Ground
11	Digital Ground
12	Ground
13	Horizontal Drive
14	Vertical Drive
15	No connection



4. System Interconnection

In This Chapter

This chapter outlines the procedures required to connect Ethernet, control panel, display monitor, reference video, source and peripheral devices, preview switching and pre-read monitoring.

The following topics are discussed in this chapter:

- [Axial/MX Interconnection](#)
- [Connecting Axial/MX into your Edit Environment](#)
- [System Power Up and Status](#)

4. System Interconnection

Axial/MX Interconnection

Axial/MX Interconnection

The following topics are covered in this section:

- [Power Connection](#)
- [Edit Display Monitor Connection](#)
- [Ethernet Connection](#)
- [Control Panel Connection](#)
- [Reference Video Connection](#)
- [Printer Connection](#)
- [PC Keyboard and Mouse Connection](#)

Power Connection

■ Use the following steps to connect system power:

1. On the **Comms Chassis** and **Display Chassis**, ensure that the voltage is set properly. In Chapter 2, refer to the “[Chassis](#)” section for details on each chassis’ **Voltage Selector Slide Switch**.
2. Connect an AC power cord to the **AC Power Connector** on the rear of each chassis, and then to an AC outlet.
3. For **Control Panel** power, connect one end of the 6-pin **XLR DC Power Cable** to the Control Panel’s **External Power Supply**, and the other end to the rear of the Control Panel. In Chapter 3, refer to the “[Control Panel Connections](#)” section for details on the Control Panel Power Connector.
4. Connect an AC power cord to the Control Panel’s **External Power Supply**. Do not connect the cord to an AC outlet at this time.

Edit Display Monitor Connection

■ Use the following steps to connect the Edit Display Monitor:

1. Connect an AC power cord to your selected (LCD or CRT) display monitor, and then to an AC outlet.
2. Connect the display monitor’s VGA cable to the **VGA Display Monitor** connector on the rear of the **Display Chassis**. In Chapter 3, refer to the “[Display Chassis Rear Panel Connectors](#)” section for an illustration of the **Display Chassis** rear panel.

Ethernet Connection

The **Display Chassis** and the **Comms Chassis** communicate over an Ethernet connection, using a supplied Ethernet “crossover” cable.

■ Use the following steps to connect Ethernet:

1. Connect one end of the Ethernet “crossover” cable to the **Ethernet Port (Private)** on the **Comms Chassis**. In Chapter 3, refer to the “[Comms Chassis Rear Panel Connectors](#)” section for an illustration of the **Comms Chassis** rear panel.
2. Connect the other end of the Ethernet “crossover” cable to the **Ethernet Port (Private)** on the **Display Chassis**. In Chapter 3, refer to the “[Display Chassis Rear Panel Connectors](#)” section for an illustration of the **Display Chassis** rear panel.
3. If desired (for communication with other Axial Editors or “House” devices), connect one end of a standard Ethernet cable to the **Ethernet Port (House Lan)** connector on the **Display Chassis**.
4. Connect the other end of the standard Ethernet cable to your house LAN (e.g., to an Ethernet Switch or Hub).

Control Panel Connection

The **Comms Chassis** and **Control Panel** communicate over an RS-422 cable. A 50-foot RS-422 cable is included with your Axial/MX Editor.

■ Use the following steps to connect the Control Panel:

1. Connect one end of the supplied 50-foot RS-422 cable to the **Control Panel Port** on the rear of the **Comms Chassis**. In Chapter 3, refer to the “[Comms Chassis Rear Panel Connectors](#)” section for an illustration of the **Comms Chassis** rear panel.
2. Connect the other end of the RS-422 cable to the **Control Panel Port** on the rear of the **Control Panel**. In Chapter 3, refer to the “[Control Panel Connections](#)” section for an illustration of the **Control Panel** rear panel.

4. System Interconnection

Axial/MX Interconnection

Reference Video Connection

In the Axial/MX editor, you can set the reference standard to NTSC (525), PAL (625), or Auto detect. This procedure is performed in the **Init Manager Window**, under the “Miscellaneous” category. In Appendix A of the Axial/MX User’s Guide, refer to the “**Miscellaneous**” section for details on setting the reference initialization value.

Once the standard is set, the system must be rebooted.

■ **Use the following steps to connect reference video for 525, 625, 24P or “Auto” detect configurations:**

1. Connect the desired reference signal:
 - ~ For NTSC (525) or PAL (625), connect the appropriate reference color black signal (NTSC or PAL) to the **525/AUTO** BNC connector on the **Comms Chassis** rear panel.
 - ~ For 24P, connect a 24-frame biphasic signal to the **525/AUTO** BNC connector on the **Comms Chassis** rear panel.

In Chapter 3, refer to the “[Reference Video Card](#)” section for an illustration of the card.

Important

Even though both 525 and 625 BNC connectors are provided, only use the top **525/AUTO** connector pair for 525, 625, 24P and “Auto” detect reference connection.

2. Terminate the reference loop with at 75Ω terminator on the other **525/AUTO** BNC connector.

Notes

Please note:

- For NTSC, the reference signal must conform to EIA RS-170A standards. Black Burst (Color Black) or Color Bars are recommended.
- It is not recommended that you loop reference to another device.

Note

An SDI reference is also required with the Live Video Option. This SDI reference video must match the frame rate and format of the video sources and can be live video input. If a live input is used, it must be synchronous.

Printer Connection

The Axial/MX **Display Chassis** provides serial and parallel printer ports that enable you to print Axial files, such as EDLs. If desired, you can also print files to a networked printer via the “House” Ethernet connection. Refer to the [“Ethernet Connection”](#) section for Ethernet connection instructions.

■ **Use the following steps to connect a printer:**

1. Select the printer that you wish to install:
 - ~ For a parallel printer, connect the printer’s 25-pin D cable to the **Parallel Printer Port** on the rear of the **Display Chassis**.
 - ~ For a serial printer, connect the printer’s 9-pin D cable to the **Com 1 Port** on the rear of the **Display Chassis**.

In Chapter 3, refer to the [“Display Chassis Rear Panel Connectors”](#) section for an illustration of the **Display Chassis** rear panel.

2. Configure the printer through Windows NT. Refer to the [“PC Keyboard and Mouse Connection”](#) section for instructions on using the Maintenance Keyboard to access Windows NT. Refer to your Windows NT User Manuals for printer configuration details.
3. Once properly configured, print a test EDL. In Chapter 5 of the Axial/MX User’s Guide, refer to the “List I/O” section for EDL printing instructions.

Note

The **Parallel Printer Port** can also be used to connect an external ZIP drive. If you use this method, the ZIP drive has a parallel “loop” connector that enables a parallel printer to be connected simultaneously. Thus, the Display Chassis’ **Parallel Printer Port** can be daisy-chained to both a ZIP drive and a printer.

4. System Interconnection

Axial/MX Interconnection

PC Keyboard and Mouse Connection

The basic Axial/MX system includes a PC keyboard and mouse that can be connected to either the **Display Chassis** or the **Comms Chassis**.

- When connected to the **Display Chassis**, you have the ability to access Windows NT[®] and configure printers or update Axial system software.
- When connected to the **Comms Chassis**, qualified system engineers can perform maintenance using the VxWorks output.

■ Display Chassis — use the following steps:

1. Connect the supplied “splitter” cable to the **Keyboard/Mouse Port** on the rear of the **Display Chassis**. In Chapter 3, refer to the “[Display Chassis Rear Panel Connectors](#)” section for an illustration of the **Display Chassis** rear panel.
2. Connect the PC keyboard’s cable to the purple end of the splitter cable marked with the “**Keyboard**” symbol.
3. Connect the mouse cable to the green end of the splitter cable marked with the “**Mouse**” symbol.
4. Once the system is powered up (as described in the “[System Power Up and Status](#)” section), you can access Windows NT by pressing the “**Windows**” button on the keyboard.



- ~ For printer configuration, click **Start > Setting > Printers** to access the **Printers Window**. Refer to your Windows NT User Manuals for printer configuration details.
- ~ For software updates, contact Axial Technical Support.

■ Comms Chassis — use the following steps:

1. Connect the supplied “splitter” cable to the **Keyboard/Mouse Port** on the rear of the **Comms Chassis**. In Chapter 3, refer to the “[Comms Chassis Rear Panel Connectors](#)” section for an illustration.
2. Connect the PC keyboard’s cable to the purple end of the splitter cable marked with the “**Keyboard**” symbol.
3. Connect the mouse cable to the green end of the splitter cable marked with the “**Mouse**” symbol.
4. For maintenance procedures, contact Axial Technical Support.

Note

For increased flexibility in the edit suite, you may configure your system with an infrared PC keyboard and RF mouse. These items may be purchased online or from a computer retailer.

Connecting Axial/MX into your Edit Environment

Once the basic Axial/MX system interconnections have been made, you will need to connect to the other components in your edit environment to make your system function efficiently.

The following topics are discussed:

- [Comms Port Connections](#)
- [Live Video Connections](#)
- [Video Preview Switching Methods](#)
- [Audio Preview Switching Methods](#)
- [Pre-read Preview and Record Pass Monitoring](#)

Comms Port Connections

To provide editor control of equipment in your facility from the Axial/MX, you must connect RS-422 cables from the **Device Control Comms Ports** on the rear of the **Comms Chassis** to the RS-422 serial communications ports on the equipment to be controlled. These ports may be labeled **Remote, Auxiliary, Editor** (etc.) on the various devices.

External equipment that can be controlled includes audio mixers, video switchers, video routers, DVEs (such as Accom Dveous/MX), DDRs (such as the Accom APR•ClipStore), servers (such as the Accom ProServ), VTRs, ATRs and more.

■ **Use the following steps to connect device communications:**

1. Using a standard RS-422 cable, connect one end of the cable to the serial communications port on the selected external device. Refer to your device's technical manual to determine where to connect the serial cable.
2. Connect the other end of the RS-422 cable to one of the 12 **Serial Device Ports** on the rear of the **Comms Chassis**. (If the serial port option has been purchased, 24 ports will be available.) In Chapter 3, refer to the "[Comms Chassis Rear Panel Connectors](#)" section for an illustration of the **Comms Chassis** rear panel.
3. For the selected device, make a note of the serial port number on the rear of the **Comms Chassis**. This port number will be required when you assign the device using the **Assign Manager Window**.
4. Repeat steps 1 through 3 for each external serial device to be connected.

Note

There is a 4000 ft. maximum length for RS-422 cable runs.

In Chapter 3 "**System Configuration**" of the Axial/MX User's Guide, refer to the "**Device Configuration**" section for details on using the **Assign Manager Window**.

4. System Interconnection

Connecting Axial/MX into your Edit Environment

Live Video Connections

The Axial/MX **Live Video Option** includes assignable SDI video inputs.



Figure 4-1. Display Monitor Live Video Inputs

Note

This section assumes that the Live Video board is already installed and does not offer instructions on installing the board. If installing the live video board, please refer to the instructions that are included with the board. Or contact Accom technical support.

Please note:

- Typically, the larger video window on the Axial/MX displays live video from the master recorder or video switcher program output.
- The smaller video input displays on the Axial/MX screen can display live video from up to 3 other video feeds, typically Aux busses from the video switcher. These smaller windows display the currently selected source device.

On the display, there are six, smaller source video windows — four of which can be active at any time:

- Depending on room configuration, one is the active window (currently selected source), while the other five are stills (last active frame) to provide visual representation of each source device. However, if 4 live video feeds are used, up to 3 source windows could be active at one time.
- Windows 1 through 5 display sources A through E.
- The sixth window displays sources F through J and Aux sources 1 through 9.

4. System Interconnection

Connecting Axial/MX into your Edit Environment

- In all operation modes, the video windows remain the same size. However, in HD mode, video windows will be “letterboxed,” with black at the top and bottom.
- The live video board has 5 video inputs. Inputs 1-4 support live video inputs in either SD or HD (including 24p). Input 5 is an SDI input that must be connected and be at the same line standard as the current live inputs.

For proper viewing of all live video sources, several connection configurations can be used, as outlined in the following sections:

- [Connections using Video Switcher AUX Busses](#)
- [Connections using a Video Router \(Matrix\)](#)
- [Connections using Alternate Video Feed Options](#)

Connections using Video Switcher AUX Busses

- Use the following figure for reference with the “AUX Bus” method for live video connections:

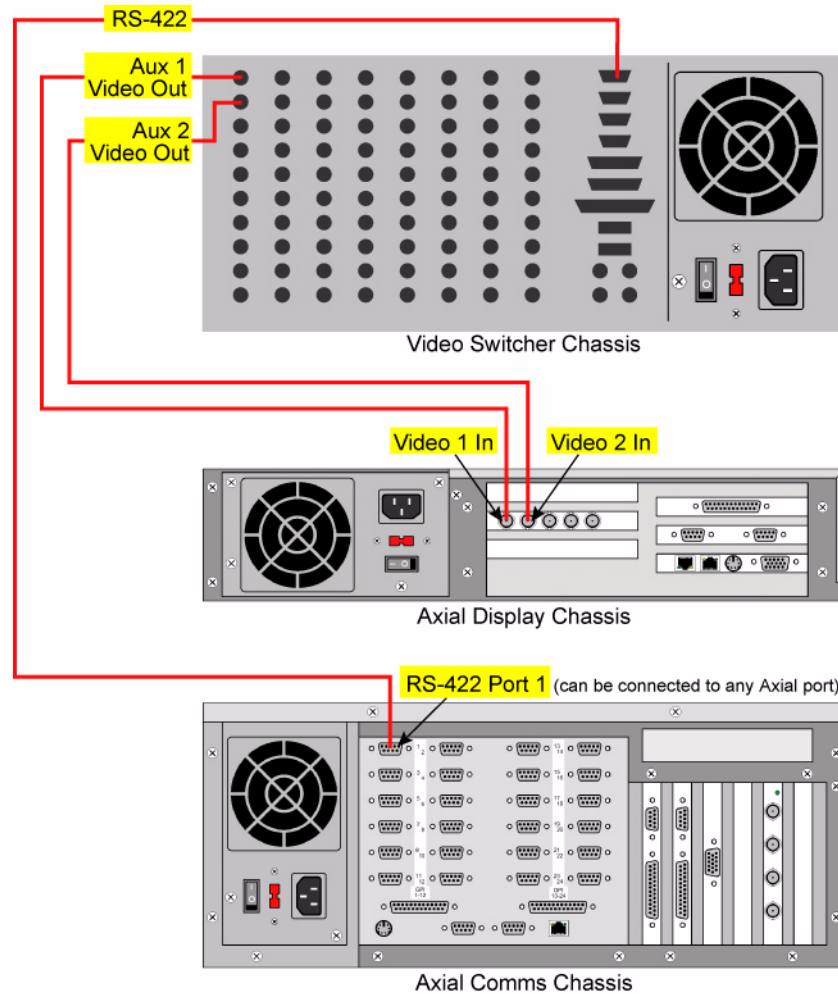

Figure 4-2. Live Video fed by two Aux Busses

4. System Interconnection

Connecting Axial/MX into your Edit Environment

Axial/MX can control video switcher Aux busses that enable selection of the proper source video for the display monitor's live video windows. Axial/MX has 4 live video inputs, so it is possible to connect and control up to 4 video switcher Aux busses.

Note

The typical installation will use a total of 4 Aux busses: 2 to feed the source windows, 1 to feed the record window and a fourth to be used for preview monitoring. Refer to the [“Video Preview Switching Methods”](#) section.

Connections using a Video Router (Matrix)

- Use the following figure for reference with the “Video Router” method for live video connections:

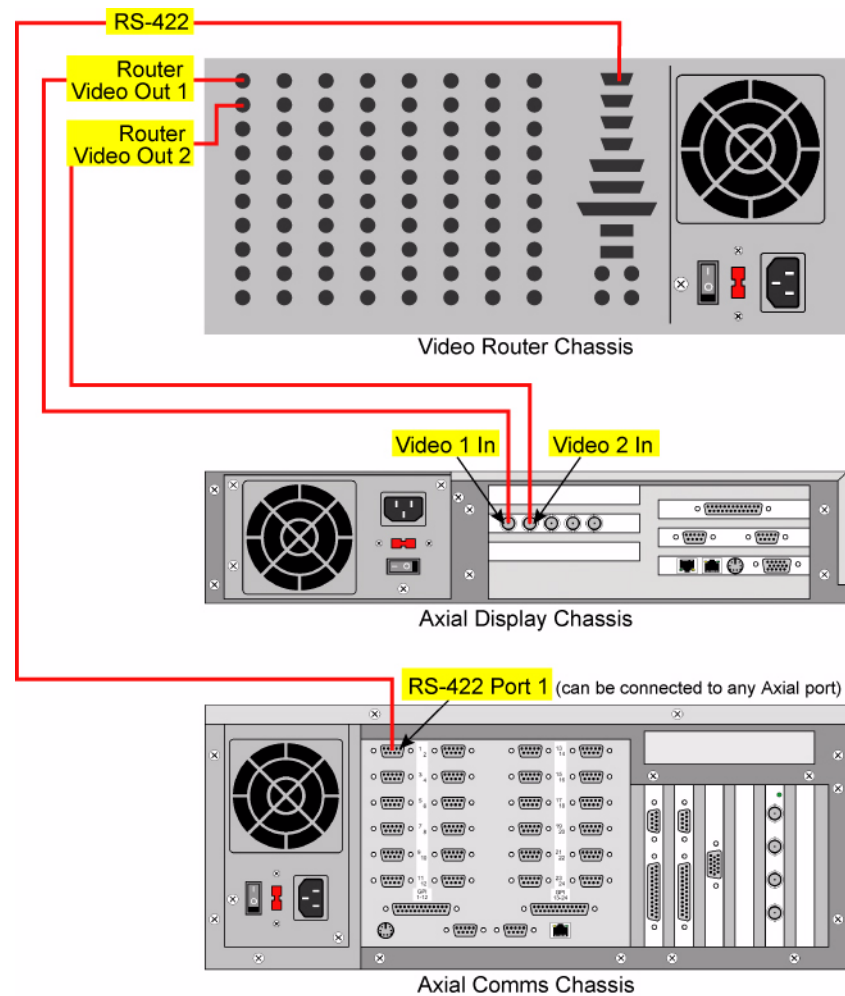

Figure 4-3. Live Video fed by Video Router (Matrix) Outputs

Axial/MX can control video router outputs that enable selection of the proper source video for the display monitor's live video windows. Axial/MX has 4 live video inputs, so it is possible to connect and control up to 4 video router outputs.

Note

The typical installation will use a total of 4 router crosspoints: 2 to feed the source windows, 1 to feed the record window and a fourth to be used for preview monitoring. Refer to the “[Video Preview Switching Methods](#)” section.

Connections using Alternate Video Feed Options

If multiple aux busses or video router (matrix) outputs are not available for feeding the live video inputs, alternate options may be used to feed the Master Window. One switcher aux bus or video router (matrix) output is still desired to feed the source window video input.

Following are several options:

- A preview monitor output may be fed to the Master Window input. This preview monitor output may be a video router (matrix) output, switcher aux bus or preview bus, or external preview switcher. In this manner, the Master Window would always have the same display as the preview monitor, rather than displaying master video when a source device is selected.
- The master record device’s video output may be connected directly to an assignable video input. Note that with this method, if the recorder is changed, the Master Window will not update automatically to display the new recorder video — the window feed must be changed manually.

Video Preview Switching Methods

For source selection and preview (or record) monitoring, Axial/MX will select the appropriate video switcher output or master recorder that feeds the preview monitor — based on the preview switching method used. The figure below shows the display intervals during preview and record edit passes:

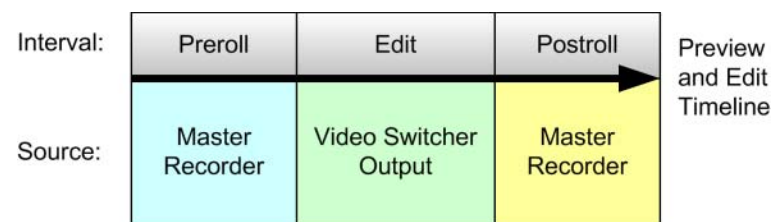

Figure 4-4. Video Preview Switching Display Intervals

The Axial/MX editor includes comprehensive preview switching control capabilities. The following Video Preview Switching methods are supported:

- [Video Switcher Preview Bus / Aux Bus](#)
- [Video Router \(Matrix\)](#)
- [Record Machine EE](#)
- [External Preview Switcher](#)

4. System Interconnection

Connecting Axial/MX into your Edit Environment

Video Switcher Preview Bus / Aux Bus

Axial/MX can control a video switcher's dedicated Preview Bus or an Aux Bus for edit preview monitoring on the main edit suite monitor. For video switchers that include a dedicated **Preview Bus** (not to be confused with **Preset Bus**), this is the preferred option. If the video switcher does not include a dedicated Preview Bus, an **Aux Bus** may be used.

Video Router (Matrix)

A single video router (matrix) output can be controlled by Axial for edit preview monitoring on the main edit suite monitor.

Important

Please note:

- The switcher program output **MUST** be fed back into the video router (matrix) as an input source for it to function properly as a preview monitor.
- For field accurate preview monitoring, a video router (matrix) must be capable of “deterministic switching,” or responding to connect commands with exactly the same delay at all times, regardless of other matrix “traffic.”

Record Machine EE

The Axial/MX can perform Record Machine EE preview switching for preview monitoring on the main edit suite monitor. If you prefer (or if no other video preview monitoring options are available), you can use Record Machine EE for video preview monitoring.

During the record interval, the record machine output is switched to display the input video signal (video switcher program output).

There are limitations to this method when performing pre-read edits. Please see the [“Pre-read Preview and Record Pass Monitoring”](#) section for details.

External Preview Switcher

An External Preview Switcher can be controlled by Axial for preview monitoring on the main edit suite monitor. With the advent of video switchers equipped with multiple preview/aux busses, this is a less commonly used method.

A Preview Switcher is a dedicated external box, typically with two inputs and one output. One input is dedicated to the record device — the other is dedicated to the video switcher / audio mixer program output. A Preview Switcher may support video and/or audio, and may handle digital or analog signals.

The user must ensure that the proper inputs are fed to the preview switcher. This is typically accomplished by manual button selections. When re-configuring record devices, manual re-selection of the record input is typically required.

Audio Preview Switching Methods

For source selection and preview (or record) edits, Axial will select the appropriate audio mixer output or master recorder feeding the preview monitor based on the preview switching method used. The following Audio Preview Switching methods are supported:

- [Audio Mixer Preview Bus](#)
- [Record Machine EE](#)
- [External Preview Switcher](#)
- [Audio Router \(Matrix\)](#)

Audio Mixer Preview Bus

The Axial/MX can control an audio mixer's Preview Bus for audio edit preview monitoring. This is the preferred method for audio preview monitoring.

Record Machine EE

When a video switcher or router (matrix) is used for video preview switching, Record Machine EE preview switching is normally disabled. An exception is if you do not have an Axial-controlled audio preview switcher. Normally, audio preview monitoring is handled by an audio mixer under Axial control. If an audio mixer is not available, Record Machine EE preview switching is the alternative.

Pvw Bus / Aux Bus / Router and Record Machine EE Preview Switching may be enabled at the same time. The result for video preview edits will not change.

- During preroll, the master output will be viewed directly via the selected preview switching output feeding the preview monitor.
- During the edit interval, the master machine will be switched to EE (audio mixer program output), but at the same time, the selected preview switching output will switch to video switcher program output.
- During postroll, the master machine will be switched out of EE, and at the same time, the selected preview switching output will switch back to the master output.

There are limitations to this method when performing pre-read edits. Please see the "[Pre-read Preview and Record Pass Monitoring](#)" section for details.

External Preview Switcher

An External Preview Switcher can be controlled by Axial for audio edit preview monitoring. With the advent of audio mixers equipped with a preview bus, this is a less commonly used method for preview monitoring.

A Preview Switcher is a dedicated external box, typically with two inputs and one output. One input is dedicated to the record device — the other is dedicated to the video switcher/audio mixer program output. A Preview Switcher may support video and/or audio, and may handle digital or analog signals.

The user must ensure that the proper inputs are fed to the preview switcher. This is typically accomplished by manual button selections. When re-configuring record devices, manual re-selection of the record input is typically required.

4. System Interconnection

Connecting Axial/MX into your Edit Environment

Audio Router (Matrix)

Axial/MX is capable of supporting audio preview switching via an Audio Router (Matrix). In practice, this method is not commonly used. For more information on router (matrix) connections please see the “[Video Router \(Matrix\)](#)” section.

Pre-read Preview and Record Pass Monitoring

For video and audio pre-read preview and edit passes, preview monitoring is the same as for non-pre-read edits. During pre-read record passes, Axial normally switches away from the record device to display input video and/or audio signals, rather than displaying record machine confidence playback. This is done for record devices that are not physically capable of displaying confidence or EE playback during a pre-read record pass.

- To view the proper video during the record interval of a pre-read edit, video preview monitoring must be handled by a video switcher preview bus, a video switcher bus, a video router (matrix) or an external preview switcher.
- To monitor the proper audio during the record interval of a pre-read edit, audio preview monitoring must be handled by an audio mixer preview bus, an audio mixer aux bus, and audio router (matrix) or an external preview switcher.

A drawback of Record Machine EE preview monitoring is that during a pre-read record pass, it is not possible to monitor input video and audio due to physical limitations of the record device.

System Power Up and Status

The following topics are discussed in this section:

- [Prerequisites](#)
- [System Power Up](#)
- [System Status](#)
- [System Reboot](#)

Prerequisites

As a prerequisite, ensure that you have made all system connections as described in these sections:

- [Axial/MX Interconnection](#)
- [Connecting Axial/MX into your Edit Environment](#)

System Power Up

With all connections made, power can be applied as described below.

■ **Use the following steps to apply power to each component:**

1. **Control Panel** — Turn on Control Panel power by plugging the AC power cord from the **External Power Supply** into an AC outlet.
2. **Edit Display Monitor** — Press the power switch on your selected Edit Display Monitor (CRT or LCD).
3. **Comms Chassis** — Use the following steps:
 - a. Ensure that the **MAIN POWER** switch on the rear panel is in the **ON** position.
 - b. On the front panel, toggle the **POWER** switch.

Important

The **STANDBY POWER** switch on the front of the **Comms Chassis** is a toggle. It does not have a specific **ON** or **OFF** position. Power is either toggled **ON** or **OFF**.
In the event of a power outage, the chassis is toggled **OFF**.
When power is restored, you must toggle the **POWER** switch again.

4. **Display Chassis** — Use the following steps:
 - a. Ensure that the **MAIN POWER** switch on the rear panel is in the **ON** position.
 - b. Inside the front panel, toggle the **STANDBY POWER** switch to the **ON** position.
5. Turn on power to all peripheral equipment.

4. System Interconnection

System Power Up and Status

System Status

The following topics are discussed:

- [Display Chassis Status](#)
- [Comms Chassis Status](#)

Display Chassis Status

The figure below illustrates the Status LEDs on the Display Chassis front panel.



Figure 4-5. Display Chassis Status LEDs

- The green **PWR LED** lights when power is on.
- The red **HDD LED** lights to indicate hard disk activity.

Comms Chassis Status

The figure below illustrates the green **POWER LED** on the Comms Chassis front panel. This LED lights when chassis power is on.



Figure 4-6. Comms Chassis Power LED

On the front panel, there are also four rows of communication status LEDs:

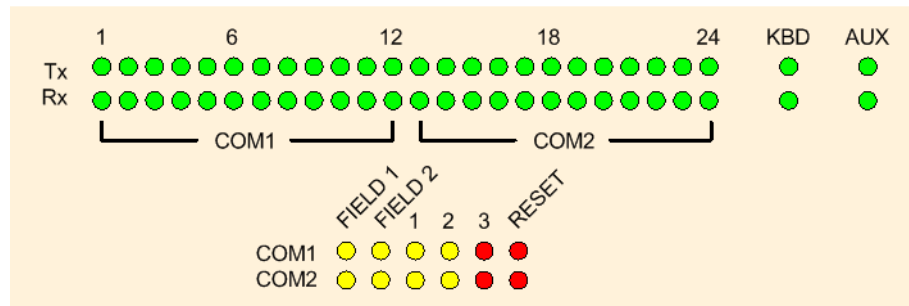

Figure 4-7. Comms Chassis Communication Status LEDs

The top two rows display **Transmit (Tx)** and **Receive (Rx)** status for each RS-422 Comms Port including the Control Panel (**KBD**) and **AUX** ports.

4. System Interconnection

System Power Up and Status

- The **COM 1** section represents the standard Comms Port board (Comms Ports 1 thru 12). The **COM 2** section represents the optional Comms Port board (Comms Ports 13 thru 24).

For example, if a port's **Tx** LED is on and the associate **Rx** LED is not, there may be one of several causes:

- ~ The RS 422 cable is bad.
 - ~ The selected machine is not on.
 - ~ The assigned protocol does not match the device's protocol.
- The bottom two rows report field status and comms port operation status for the **COM 1** and **COM 2** boards. Descriptions are listed in the table below.

Table 4-1. Communication Status LED Descriptions

LED	Color	Description
FIELD 1	Yellow	Field 1 active. Turns on at start of processing Field 1, off at end.
FIELD 2	Yellow	Field 2 active. Turns on at start of processing Field 2, off at end.
1	Yellow	ON indicates valid video reference present.
2	Yellow	Flashes during boot as each port is initialized. Remains ON if all ports initialize properly.
3	Red	ON indicates reference lock error.
RESET	Red	ON when the Comms Chassis is booting.

System Reboot

System reboot can be accomplished from the Axial/MX Control Panel, or each chassis can be rebooted individually by using the front panel **RESET** switch.

5. Engineering Specifications

In This Chapter

This chapter provides comprehensive tables of Axial/MX specifications. The following tables are provided:

- [Comms Chassis Device Control](#)
- [Display Chassis General Interface](#)
- [Comms Chassis General Interface](#)
- [Display Chassis Video I/O](#)
- [Reference Video](#)
- [Display Chassis Physical and Electrical](#)
- [Comms Chassis Physical and Electrical](#)
- [Control Panel Physical and Electrical](#)

5. Engineering Specifications

In This Chapter

Comms Chassis Device Control

The table below lists **Comms Chassis** device control specifications:

Table 5-1. Comms Chassis Device Control Specifications

Parameter	Specification	Note
Serial	12 RS-422 ports standard, expandable to 24	D9 female
GPI	12 GPI outputs, expandable to 24	D25 female

Display Chassis General Interface

The table below lists **Display Chassis** general interface specifications:

Table 5-2. Display Chassis General Interface Specifications

Parameter	Specification	Note
Ethernet (private)	100BaseT interlink to Comms Chassis	RJ-45
Ethernet (house LAN)	1000BaseT (gigabit) / 100BaseT	RJ-45
Serial printer port	RS-232	D9 female
Parallel printer port		D25 female
Keyboard	Maintenance port	PS/2
Mouse	Maintenance port	PS/2
Auxiliary serial ports	2x	D9 male

Comms Chassis General Interface

The table below lists **Comms Chassis** general interface specifications:

Table 5-3. Comms Chassis General Interface Specifications

Parameter	Specification	Note
Control Panel port	RS-422	D9 female
Ethernet (private)	100BaseT interlink to Display Chassis	RJ-45
VGA	Maintenance display output	HD15 female
Keyboard	Maintenance port	PS/2
Mouse	Maintenance port	PS/2
Auxiliary serial port	1x	D9 male
Auxiliary parallel ports	2x	D25 female

Display Chassis Video I/O

The table below lists **Display Chassis** video I/O specifications when the **Live Video Option** is installed:

Table 5-4. Display Chassis Video I/O Specifications

Parameter	Specification	Note
Monitor Output	1 x VGA, 1280 x 1024 resolution	HD15 female
Video Inputs	5 x 601 (SDI)	BNC

Reference Video

The table below lists reference video specifications:

Table 5-5. Reference Video Specifications

Parameter	Specification	Note
Display Chassis	1 x serial reference video input if Live Video Option is installed.	BNC
Comms Chassis	1 x 525/625/24p/Auto, high-impedance looping.	BNC

Display Chassis Physical and Electrical

The table below lists **Display Chassis** physical and electrical specifications:

Table 5-6. Display Chassis Physical and Electrical Specifications

Parameter	Specification	Detail
Display Chassis	Dimensions	3.5" High (8.89 cm), 2 RU
		17.0" Wide (43.18 cm)
		18.5" Deep (46.99 cm)
	Weight	28 lbs / 12.7 kg.
	Power	Switchable 90-132 / 180-264 VAC; < 250W

5. Engineering Specifications

In This Chapter

Comms Chassis Physical and Electrical

The table below lists **Comms Chassis** physical and electrical specifications:

Table 5-7. Comms Chassis Physical and Electrical Specifications

Parameter	Specification	Detail
Display Chassis	Dimensions	7.0" High (17.78 cm), 4 RU
		17.0" Wide (43.18 cm)
		24.5" Deep (62.23 cm)
	Weight	25 lbs / 11.4 kg.
	Power	Switchable 90-132 / 180-264 VAC; < 250W

Control Panel Physical and Electrical

The table below lists **Control Panel** physical and electrical specifications:

Table 5-8. Control Panel Physical and Electrical Specifications

Parameter	Specification	Detail
Control Panel	Dimensions	6.5" High (16.5 cm)
		31.0" Wide (78.74 cm)
		12.75" Deep (32.39 cm)
	Weight	17 lbs. / 7.7 kg.
	Power	Universal input, 90-264 VAC; < 42W



Index

Numerics

24P	9
reference	28
3.5" Floppy Drive	10
525/NTSC reference	28
625/PAL reference	28

A

AC	
power connector, comms chassis	27
power connector, display chassis	24
precautions	12
Accom	
contact	4
technical support	4
world wide web	4
Acknowledgements	ii
Air	
filter, display and comms chassis	15
flow, display and comms chassis	15
Architecture, chassis	6
Audio	
mixer preview bus	49
preview switching	49
router matrix preview switching	50
Auxiliary com port, comms chassis	28
Axial	
2020 and 2010	7
forum, Editsuite.com	4
installation	1
specfile resources	4

B

Brackets, shipping	13
--------------------------	----

C

CD-ROM drive	10
display chassis	18

Chassis architecture	6
Color black	9
Com	
1, display chassis	25
2, display chassis	25
Comms Chassis	
AC power connector	27
air filter	15
auxiliary com port	28
connections	8
control panel port	27
cooling and airflow	15
device control specifications	56
dimensions	19
end support plates	20
Ethernet link, private	27
exhaust fan	26
floppy drive	19
general interface specifications	56
GPI outputs 1-12, 13-24	27
ID label	28
interconnection	5
keyboard/mouse port	27
main power switch	26
maintenance	10
operating system	7
physical and electrical specifications	58
power	14
rack mount	20
rack mounting	19
rear panel connectors	26
reference LED	28
reference video card	28
serial ports 1-12, 13-24	27
side support plates	20
spare 1 and 2	27
spare 3	27, 28
status LED descriptions	53
status LEDs	52
Tx, Rx status LEDs	52
VGA monitor connector	28
voltage selector	27
Comms Ports	8
Communications	
comms ports	8

Index

- display monitor 9
- Ethernet 9
- external 8
- GPI outputs 9
- printer 9
- RS-422 9
- status LED descriptions, comms chassis 53
- Company address ii
- Compliance certifications iv
- Components, physical 6
- Composite video 9
- Connection
 - control panel 29, 39
 - display monitor 38
 - Ethernet 39
 - into edit environment 43
 - keyboard 42
 - live video 44
 - live video, alternate methods 47
 - mouse 42
 - power 38
 - printer 41
 - reference video 40
 - RS-422 comms ports 43
 - RS-422 device communications 43
 - zip drive 41
- Connector
 - Ethernet crossover pinouts 34
 - Ethernet pinouts 34
 - GPI pinouts 31
 - parallel printer pinouts 33
 - pinouts 30
 - RS-232 pinouts 32
 - RS-422 pinouts 30
 - VGA pinouts 35
- Connectors
 - comms chassis rear panel 26
 - display chassis rear panel 24
 - system 23
- Contact Accom 4
- Control Panel
 - connection 39
 - connections 29
 - dimensions 21
 - external power 7
 - external power supply 22
 - interconnection 5
 - mounting 21
 - physical and electrical specifications 58
 - placement in suite 16
 - port, comms chassis 27
 - power 14
 - power connector 29
 - serial control connector, RS-422 29
- Conventions 3
- Cooling, display and comms chassis 15
- Copyright ii
- D**
 - Data storage and transfer 10
 - Device
 - control specifications 56
 - RS-422 connections 43
 - Diagram, system 5
 - Dimensions
 - comms chassis 19
 - control panel 21
 - display chassis 17
 - Display Chassis
 - AC power connector 24
 - air filter 15
 - CD-ROM drive 18
 - com 1 and 2 25
 - cooling and airflow 15
 - dimensions 17
 - Ethernet link, house LAN 25
 - Ethernet link, private 25
 - exhaust fan 24
 - floppy drive 18
 - general interface specifications 56
 - interconnection 5
 - keyboard/mouse port 25
 - L brackets 18
 - main power switch 24
 - maintenance 10
 - operating system 7
 - parallel printer port 25
 - physical and electrical specifications 57
 - power 14
 - POWER standby switch 18
 - rack ears 18
 - rack mount 18
 - rack mounting 17
 - rear panel connectors 24
 - RESET switch 18
 - status LEDs 52
 - USB port 17, 29
 - VGA monitor connector 25
 - video I/O specifications 57
 - video inputs 24
 - voltage selector 24
 - Display Monitor
 - communications 9
 - connection 38
 - Display video windows 44
 - Drive
 - CD-ROM 10
 - floppy 10
 - hard 10

E

Editsuite.com	4
Electrical specifications	
comms chassis	58
control panel	58
display chassis	57
End support plates, comms chassis	20
Engineering specifications	55
Environmental specifications	iv
Ethernet	
connection	39
connector pinouts	34
crossover connector pinouts	34
house (LAN) link, display chassis	25
private link	9
private link, comms chassis	27
private link, display chassis	25
Exhaust Fan	
comms chassis	26
display chassis	24
External	
communication	8
power supply, control panel	22
preview switcher	48
preview switcher, audio	49

F

Fan	
exhaust, comms chassis	26
exhaust, display chassis	24
FCC compliance	iii
First Aid	iii
Floppy drive	
comms chassis	19
display chassis	18

G

General interface specifications	
comms chassis	56
display chassis	56
GPI	
connector pinouts	31
outputs	9
outputs 1-12, comms chassis	27
outputs 13-24, comms chassis	27

H

Hard Drive	10
How to	
connect control panel	39
connect display monitor	38
connect Ethernet	39
connect keyboard	42

connect live video, alternate methods	47
connect mouse	42
connect printer	41
connect reference video	40
connect RS-422 comms ports	43
connect RS-422 device communications	43
connect system power	38
connect zip drive	41
power up system	51
rack mount comms chassis	20
rack mount display chassis	18

I

ID label, comms chassis	28
Inspection	13
Installation	
AC precautions	12
installation details	11
overview	1
physical	17
recommendations	6
safety precautions	12
shipping brackets	13
site preparation	16
software	22
system connectors	23
system option keycode sheet	13
unpacking and inspection	13
Interconnection	
display and comms chassis	5
system	37

K

Keyboard	7
connection	42
infrared	16
Keyboard/mouse port	
comms chassis	27
display chassis	25
Keycode sheet, system options	13

L

L Brackets, display chassis	18
LED	
descriptions, comms chassis status	53
status, comms chassis	52
status, display chassis	52
Tx, Rx, comms chassis	52
Live video	
connection	44
connection, alternate methods	47
option	3

Index

M

Main Power Switch	
comms chassis	26
display chassis	24
Maintenance	10
comms chassis	10
keyboard and mouse	7
Modifications and shielded cables	iii
Monitor, display	7
Mounting	
control panel	21
Mouse	7
connection	42
RF	16

N

Navigating the installation guide	2
Notice	ii
NTSC	9

O

Operating System	
VxWorks	7
Windows NT	7
Option	
live video	3
RAVE	3
showcase	3
system keycode sheet	13
Options	
hardware	7
software	8
system	7
Overview, system	5

P

PAL	9
Parallel printer	
connector, pinouts	33
port, display chassis	25
Part number	ii
Physical	
components	6
installation	17
Physical specifications	
comms chassis	58
control panel	58
display chassis	57
Pinouts	30
Ethernet connector	34
Ethernet crossover connector	34
GPI connectors	31
parallel printer connector	33

RS-232 connector	32
RS-422 connectors	30
VGA connector	35

Power

connection	38
connector, control panel	29
consumption	14
control panel	14
display and comms chassis	14
information	iv
main switch, comms chassis	26
main switch, display chassis	24
standby switch, display chassis	18
supply, external, control panel	22
up, system	51

Pre-read preview and record monitoring	50
--	----

Preview switching

audio	49
audio mixer preview bus	49
audio router matrix	50
audio, external preview switcher	49
external preview switcher	48
methods	47
record machine EE	48, 49
switcher preview bus/Aux bus	48
video router matrix	48

Printer	9
connection	41

Processing, system	6
--------------------	---

R

Rack Ears	18
-----------	----

Rack mounting

comms chassis	19
display chassis	17

RAVE option	3
-------------	---

Reboot system	53
---------------	----

Receive (Rx) status LEDs	52
--------------------------	----

Recommendations, installation	6
-------------------------------	---

Record

machine EE audio preview switching	49
machine EE preview switching	48
monitoring, pre-read	50

Reference

LED, comms chassis	28
video card, comms chassis	28
video connection	40
video specifications	57
video, PAL, NTSC, 24P	9

Release Notes	22
---------------	----

RESET switch, display chassis	18
-------------------------------	----

RS-232	8
--------	---

connector	32
display chassis	25

RS-422

comms ports connection	43
------------------------	----

- communications 9
 - connector pinouts 30
 - connector, control panel 29
 - serial ports 1-12, Comms Chassis 27
 - serial ports 13-24, Comms Chassis 27
- S**
- Safety iii
 - compliance certifications iv
 - information v
 - precautions 12
 - Serial Ports 1-12, 13-24, comms chassis 27
 - ShowCase option 3
 - Side Support Plates, comms chassis 20
 - Site preparation 16
 - Software
 - installation 22
 - options 8
 - Windows NT 1
 - Spare
 - 1, comms chassis 27
 - 2, comms chassis 27
 - 3, comms chassis 27, 28
 - Specfile resources 4
 - Specifications
 - comms chassis device control 56
 - comms chassis general interface 56
 - comms chassis physical and electrical 58
 - control panel physical and electrical 58
 - display chassis general interface 56
 - display chassis physical and electrical 57
 - display chassis video I/O 57
 - engineering 55
 - environmental iv
 - reference video 57
 - Status
 - comms chassis status LEDs 52
 - display chassis status LEDs 52
 - system 51, 52
 - System
 - connectors 23
 - diagram 5
 - interconnection 37
 - option keycode sheet 13
 - options 7
 - overview 5
 - power-up 51
 - processing 6
 - reboot 53
 - status 51, 52
- T**
- Technical Support 4
 - Terms 3
 - Trademarks ii
 - Transmit (Tx) status LEDs 52
- U**
- Unpacking 13
 - USB port, display chassis 17, 29
- V**
- VGA 9
 - connector pinouts 35
 - monitor connector, comms chassis 28
 - monitor connector, display chassis 25
 - Video
 - display windows 44
 - I/O specifications, display chassis 57
 - inputs, display chassis 24
 - preview switching methods 47
 - reference card, comms chassis 28
 - reference specifications 57
 - router matrix preview switching 48
 - Video I/O
 - live video option 9
 - reference 9
 - ViewSonic
 - 20PS 7
 - 21PS 7
 - P810 7
 - Voltage
 - selection 14
 - selector slide switch 14
 - Voltage Selector
 - comms chassis 27
 - display chassis 24
- W**
- Windows NT 1
 - World Wide Web 4
- Z**
- ZIP drive 25
 - connection 41